

# HYDRAULIC BREAKER

## OPERATION MANUAL&PARTS LIST



### DANGER

For the safe and correct use of this product, please read the safety directions and operating instructions in this manual. Don' t operate this product before full acquaintance with its contents.

For the convenience of operation, please put this manual beside the corresponding breakers.

TYPE	
NUMBER	
TIME	

# DANGER!!

**DO NOT OPERATE THIS BREAKER UNLESS THE FOLLOWING SAFETY INSTRUCTIONS HAVE BEEN THOROUGHLY READ AND UNDERSTOOD! READ THIS MANUAL BEFORE INSTALLING, OPERATING OR MAINTAINING THIS EQUIPMENT!**

Flying debris from the breaker, breaker rod, rock or other material may cause serious or fatal injury to the operator. Personal protection equipment must be used.

Flying debris from the breaker, breaker rod, rock or other material may cause serious or fatal injury to bystanders. Never operate the breaker when bystanders are in the work area.

On some machines / carriers, the breaker can enter the operator's compartment if it breaks loose and swings toward the operator. Make sure that suitable impact shields are used when operating the breaker with this type of equipment.

Do not operate the breaker unless all safety decals described in this manual are in place. The decals must be inspected periodically to ensure that all wording is legible. The decals must be replaced if illegible. Replacement decals can be obtained from Factory .

When operating the breaker ear, eye and breathing protection must be used at all times.

The breaker will become very hot during operation. Allow time for breaker to cool down before touching breaker parts.

# CONTENTS

1、 Standard specifications .....	5
2、 Overall dimension .....	6
3、 Structure and main parts .....	12
4、 Setting drawing of breaker .....	13
5、 Preparation for installation and start—up of Hydraulic Breakers .....	14
6、 Operation precautions .....	15
6.1 Proper position of the rod .....	15
6.2 Alignment of the rod .....	16
6.3 Operation precautions .....	17
7、 Assembly and disassembly of breaker .....	22
8、 Repair and inspection .....	24
8.1 Maintenance of hydraulic breaker .....	24
8.2 daily inspection .....	26
8.3 Routine inspection and maintenance .....	27
8.4 Replacement of rod .....	28
8.5 Disassembly and assembly of main body of breaker.....	28
9、 Wearing range of spare parts.....	29
10、 Inspection and filling of back head nitrogen(see the next page for the detail drawing) .....	32
11、 Inspection and filling of accumulator nitrogen (see the next page for the detail drawing) .....	34
12、 Troubleshooting table .....	37
13、 Hydraulic oil .....	38
14、 Hydraulic Breaker Parts List.....	39



## 1、Standard specifications

Project	Unit	Model											
		NS40	NS45	NS53	NS68	NS75	NS100	NS140A	NS155	NS165	NS175	NS190	NS195
Weight	Side Type	90	110	147	261	354	750	1855	2630	3350	4120	4270	5600
	Top Type	89.3	118	159	266	375	746	1920	265	-	-	-	-
	Box Type	142	158	210	300	418	866	1805	2379	3130	4479	-	-
Length	Side Type	972	1080	1121	1349	1553	1936	2467	2726	2904	3158	3266	3700
	Top Type	1150	1250	1365	1589	1900	2358	2850	3315	3376	3739	-	-
	Box Type	1222	1420	1325	1587	1187	2316	2850	3315	3376	3719	3895	-
Width	Side Type	230	230	237	308	308	376	488	570	570	625	625	520
	Top Type	230	230	237	308	308	376	488	570	570	625	625	-
	Box Type	230	230	237	308	308	376	488	570	570	570	625	-
Operating Flux	l/min	15~30	20~40	25~50	40~70	50~90	80~110	120~180	180~240	200~260	210~280	240~300	280~320
Operating Oil Pressure	kg/cm <sup>2</sup>	90~120	90~120	90~120	110~140	120~150	150~170	160~180	160~180	160~180	160~180	200~230	230~250
Impact Frequency	BPM	800~1400	700~1200	600~1100	500~900	400~800	350~700	350~500	250~350	200~260	200~350	180~225	120~150
Size Of Tube	in	0.5	0.5	0.5	0.5	0.5	0.5	1	1 <sup>1</sup> / <sub>4</sub>	1 <sup>1</sup> / <sub>4</sub>	1 <sup>1</sup> / <sub>4</sub>	1 <sup>1</sup> / <sub>2</sub>	1 <sup>1</sup> / <sub>2</sub>
Rod Diameter	mm	40	45	53	68	75	100	140	155	165	175	189	195
Applicable Excavator	ton	0.8~2.5	1.2~3.0	2.5~4.5	4.0~7.0	6.0~9.0	11.0~16.0	18.0~26.0	28.0~35.0	30.0~45.0	40.0~55.0	50.0~65.0	50.0~65.0

Note: We reserve the right of revising the above parameters for product renewal without prior notification.

## 2. Overall dimension

### SIDE TYPE

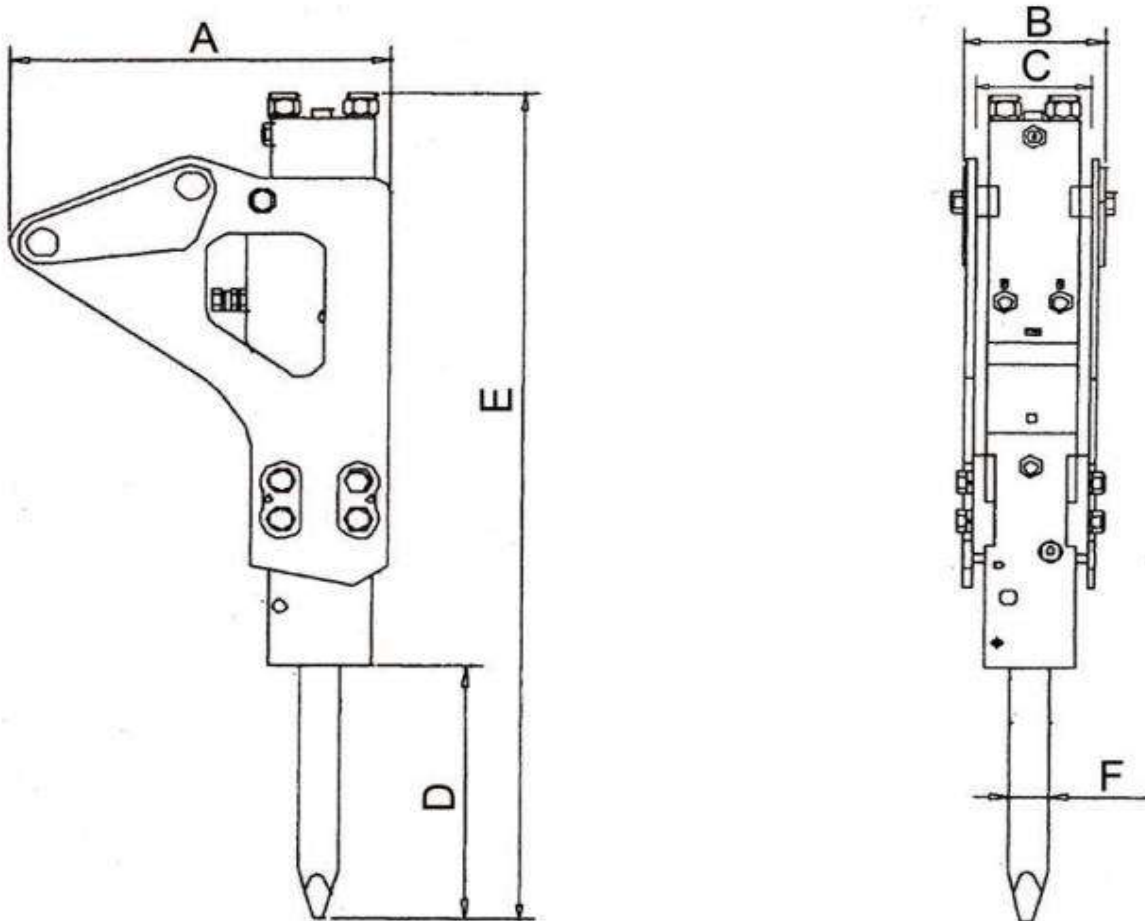

Model	A	B	C	D	E	F
NS40	400	230	120	297	977	40
NS45	425	230	130	326	1080	45
NS53	480	237	145	377.5	1121	53
NS68	690	308	220	426	1349	68
NS75	750	308	220	455	1553	75
NS85	904	350	250	500	1755	85
NS100	992	376	280	516	1936	100

## SIDE TYPE

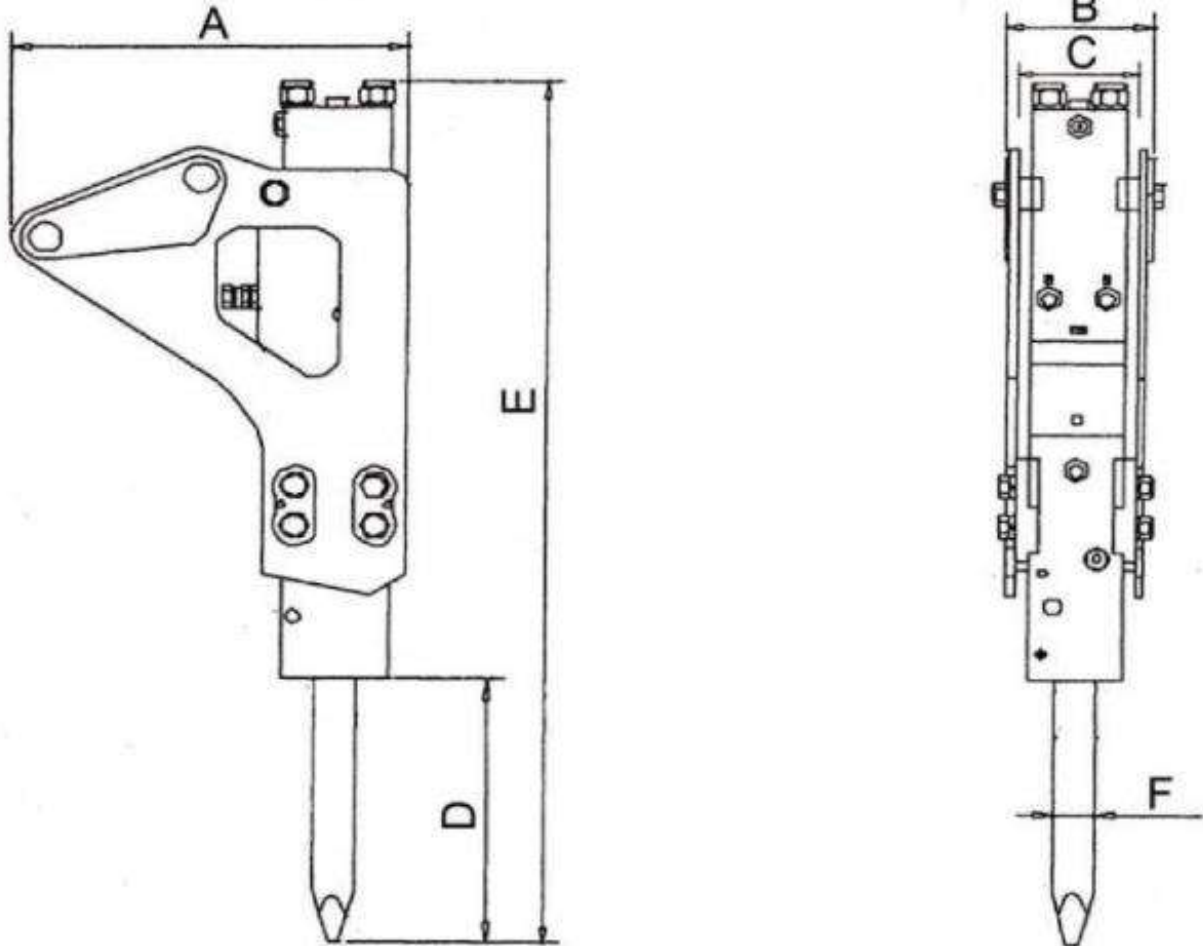

Model	A	B	C	D	E	F
NS120	1220	428	300	666	2076	120
NS135A	1228	488	360	707	2400	135
NS140A	1264	488	360	738	2467	140
NS155	1418	570	420	783	2726	155
NS165	1490	570	420	818	2904	165
NS175	1710	625	475	807	3158	175
NS185	1750	635	475	936	3223	185
NS190	1786	635	475	945	3266	189
NS195	1860	682	520	1059	3700	195

TOP TYPE

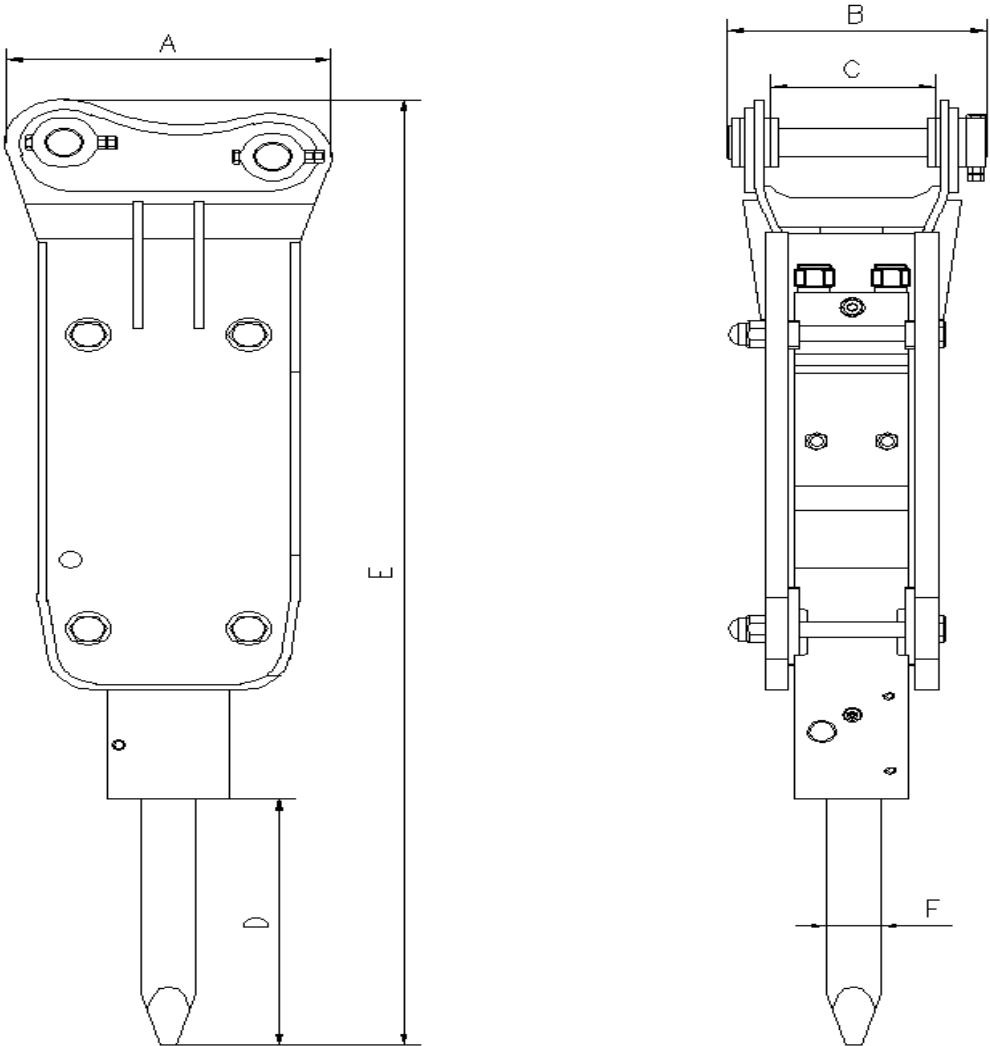

Model	A	B	C	D	E	F
NS40	300	230	120	297	1150	40
NS45	300	230	120	326	1250	45
NS53	300	237	145	377.5	1365	53
NS68	420	308	220	426	1589	68
NS75	490	308	220	455	1900	75
NS85	575	350	250	500	2060	85
NS100	610	376	280	516	2316	100

## TOP TYPE

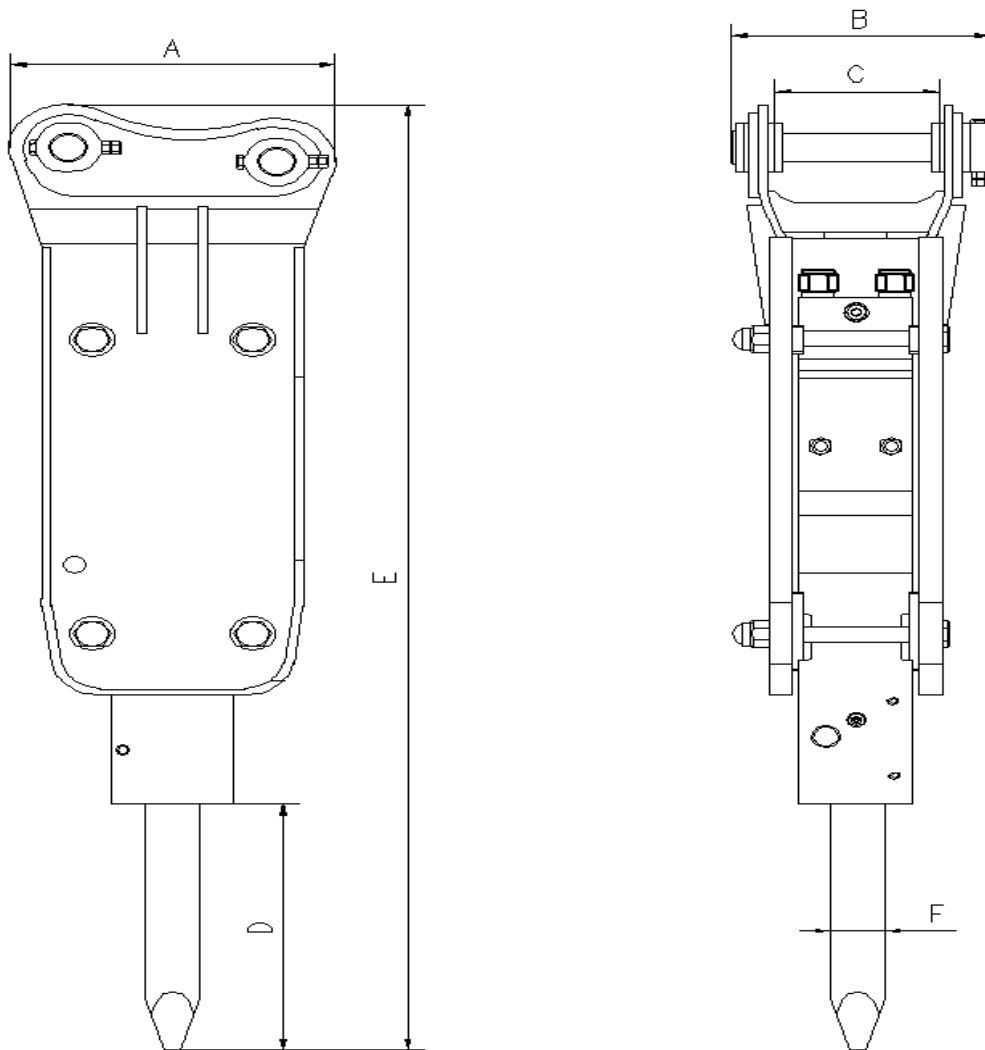

Model	A	B	C	D	E	F
NS120	650	428	300	650	2605	120
NS135A	770	488	360	480	2605	135
NS140A	770	488	360	726	2850	140
NS155	860	570	420	880	3315	155
NS165	860	570	420	816	3376	165
NS175	954	625	475	796	3719	175
NS190	954	625	475	900	3900	190

## BOX TYPE

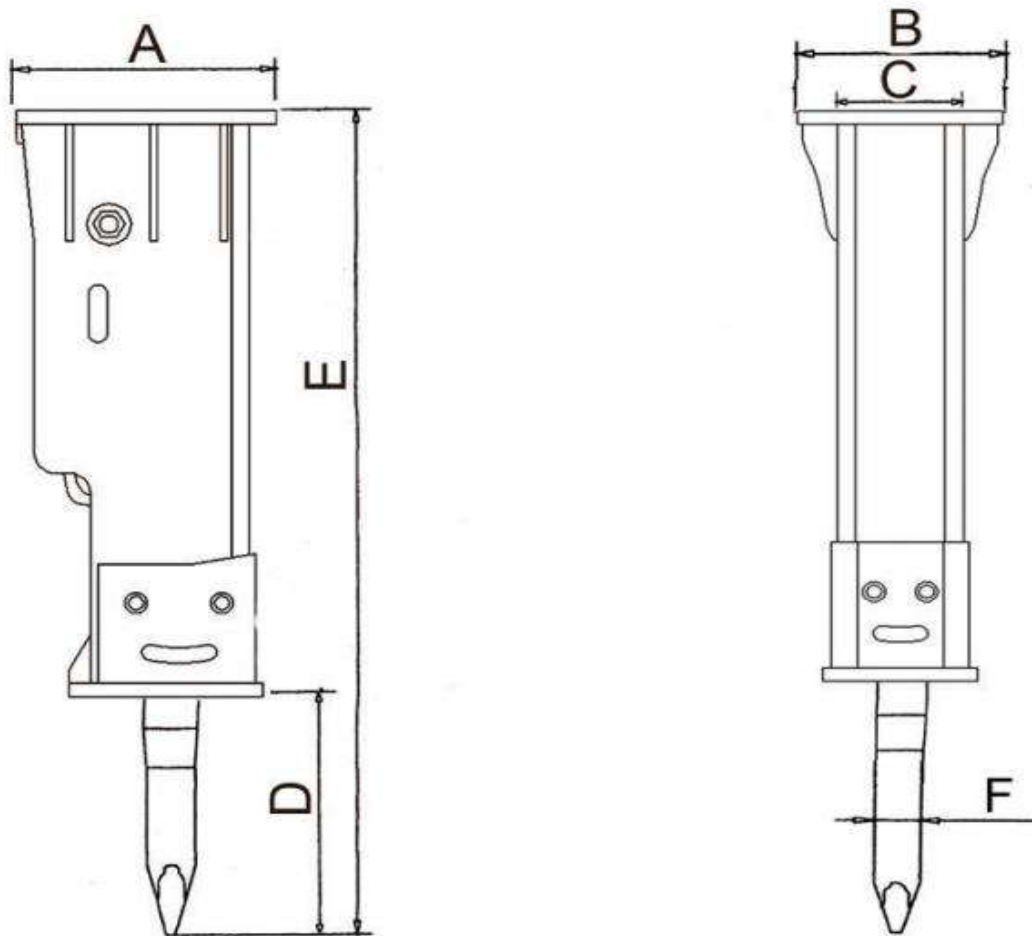

Model	A	B	C	D	E	F
NS40	340	230	120	262	1222	40
NS45	340	230	120	291	1420	45
NS53	370	237	145	342	1542	53
NS68	440	308	220	376	1609	68
NS75	504	308	220	405	1872	75
NS100	550	376	280	486	2208	100

## BOX TYPE

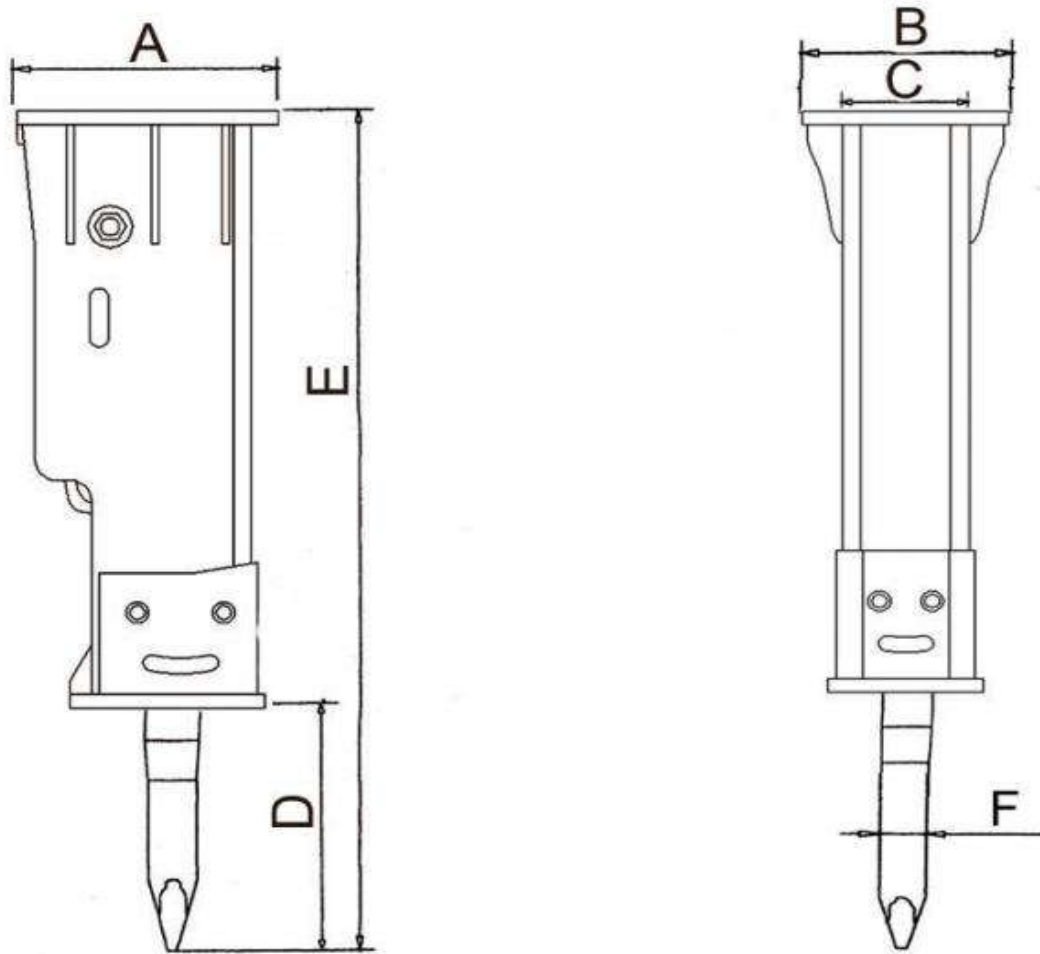

Model	A	B	C	D	E	F
NS135A	720	488	360	439	2495	135
NS140A	740	488	360	689	2798	140
NS155	854	570	420	764	3200	155
NS165	854	570	420	754	3313	165
NS175	954	625	475	739	3662	175

### 3. Structure and main parts

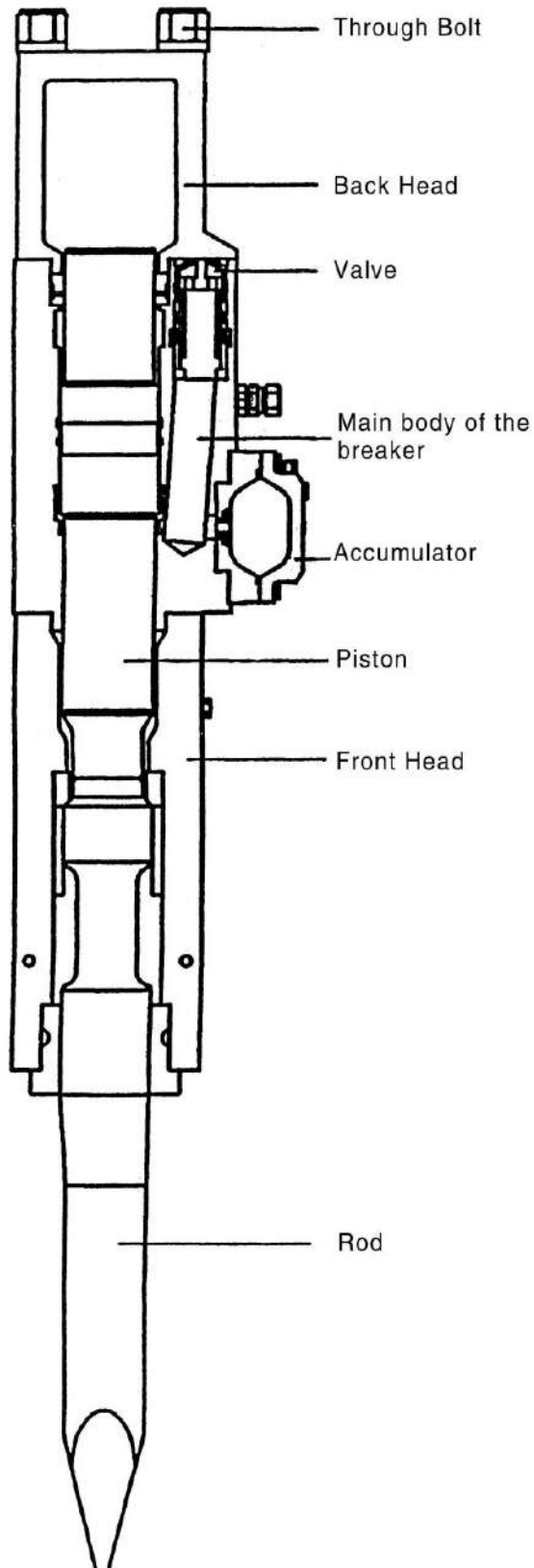

#### Through Bolt

Four main bolts tightly connecting the back head, main body of breaker and the front head.

#### Back Head

The leading role is to store nitrogen

#### Valve

Controlling the up and down movement of piston at certain frequencies.

#### Main body of the breaker-Cylinder

The heart of breaker; Containing a hydraulic circulation system to control the reciprocating movement of piston. .

#### Piston

Converting hydraulic kinetic energy to the striking energy; playing the breaking role by punching the rod .

#### Front Head

The function of front head is to support the main body of the breaker, and to save it from being damaged by the recoil force of breaking.

#### Rod

Rod itself is specially reinforced to endure the abrasion caused by direct impact. This part has three models for option: moil point type, flat type and v-wedge type.



### 5.Preparation for installation and start—up of Hydraulic Breakers

#### 1.Hydraulic Pipe Lines

As NSB hydraulic breakers are hydraulically powered from excavator which supplies source of hydraulic operating power, our breakers should be installed by competent engineer in such manner that enables maximize working performance in accordance with each characteristics of different excavators.

Before installation and start up of operating breakers, following shall be referred to carefully;

※To install and run the breaker.the base machine should be equipped with separate hydraulic pipe lines for breaker only.

Hydraulic pipe lines will be different according to the models of base machines,thereforeour engineers(or qualified local engineers)should install this breaker pipelines onto this excavator always after check up the oil pressure, oil flow rate and pressure drops thereby for each different base machine.

To make sure of long lasting breaker works, you are requested to ensure that always you must use genuine parts for such as oil hoses, pipelines, and pipeline attachments with are supplied or at least qualified by factory or local authorized distributors.

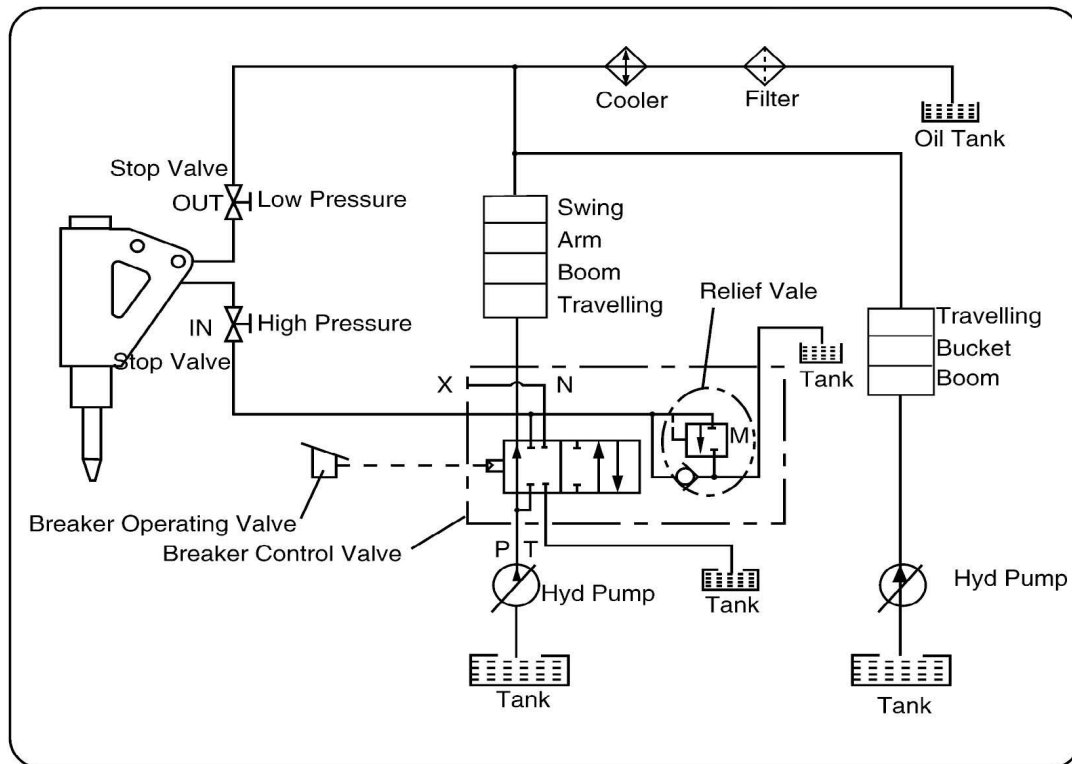

■ Set pressure of the overflow valve and pipeline back pressure

Model	Unit	NS 40	NS 45	NS 53	NS 68	NS 75	NS 85	NS 100	NS 120	NS 135A	NS 140A	NS 155	NS 165	NS 175	NS 185	NS 190	NS 195
Set pressure of the overflow valve	BAR	110-140	110-140	110-140	150-170	170-190	170-190	100-200	190-200	190-210	200-210	200-220	220-240	240-260	260-280	240-270	260-280
Back pressure	BAR	10	10	10	10	10	10	10	10	10	10	10	10	10	10	10	10

## 6. Operation precautions

### 6.1 Proper position of the rod

Proper position must be applied for an effective use of breaking force. When position is incorrect, hammering energy of the piston is too weak to break rocks. Instead, hammering force applies shocks to the breaker body, breaker, arm and boom of the base, thereby resulting in damage to those parts.

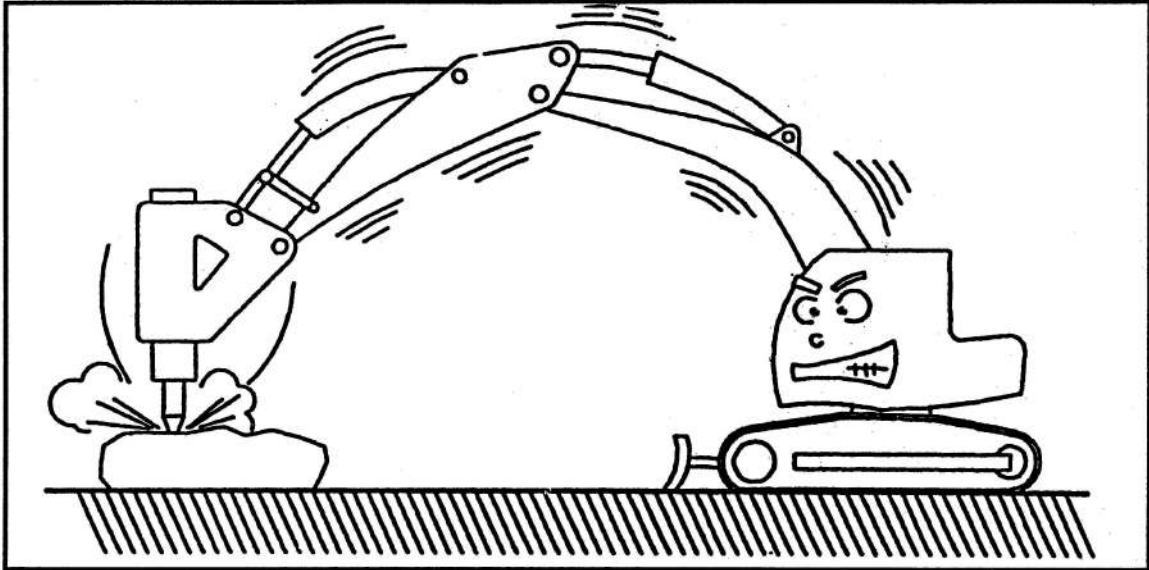

On the contrary, when position is excessive enough to break rocks with front of the base machine raised, the machine may suddenly tilt forward the moment rocks are broken. Then, the breaker body or the end of bracket may violently hit against rocks and result in damage.

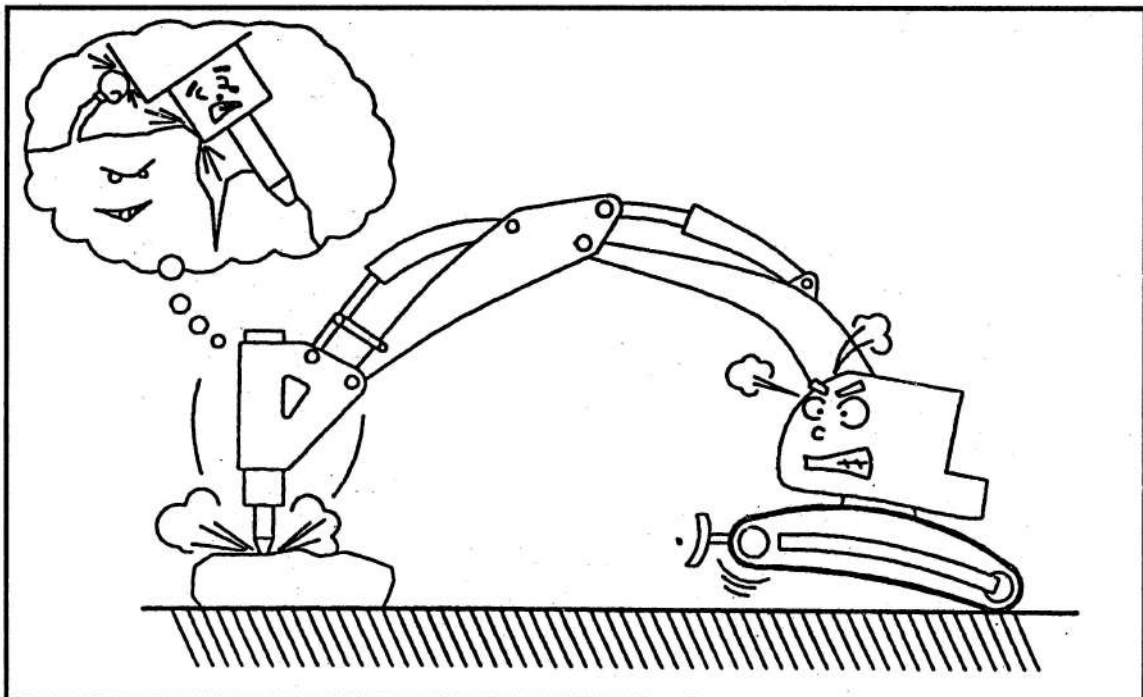

It is undesirable to carry out hammering under the below condition, because vibrations during hammering may be transmitted to tracks of the base machine .

During hammering, however, proper position must be always applied to the breaker. Special care must be taken not to hammer under abnormal condition .

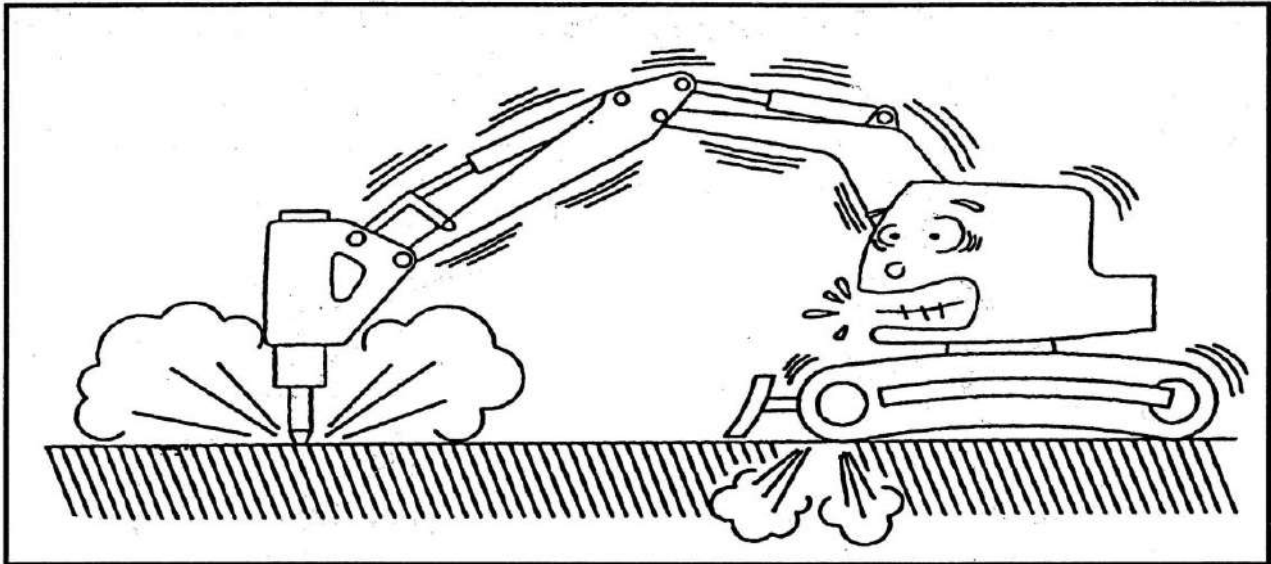

## 6.2 Alignment of the rod

Apply same direction of boom force in line with the rod and place the rod in . the rock with hammering surface as vertical as possible . If hammering surface is oblique, the rod may slip during hammering. This causes the rod to seize and to be broken and piston to be damaged . When breaking, fully stabilize the rod first and then select the point of a rock on which hammering can be performed in a stable condition .

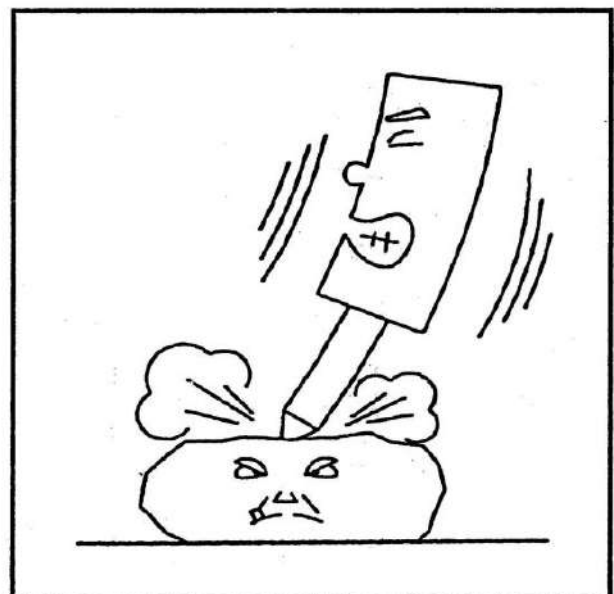
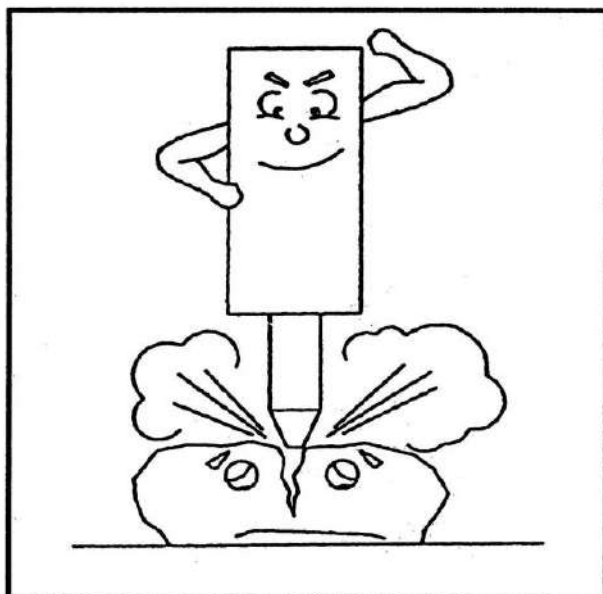

### 6.3 Operation precautions

#### (1) Stop operation as soon as hoses vibrate excessively

Excessive vibration of high and low--pressure hoses of breaker calls for an instant disassembly and repair. Contact the nearest service station appointed by FACTORY For caution' s sake,check oil leakage at back head.The operator is required to pay attention to following points during operation.

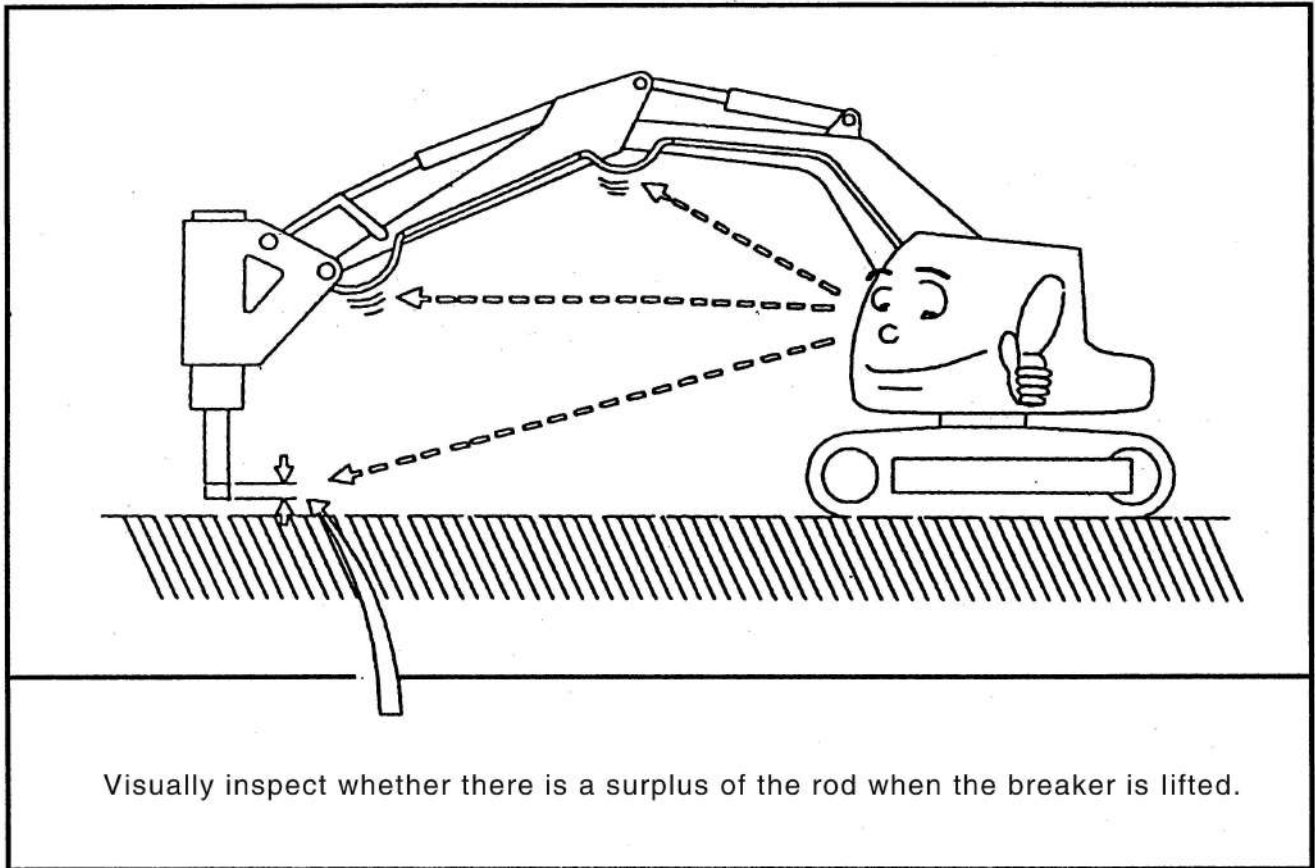

#### (2) Avoid all blank hammering

As soon as rocks are broken, stop hammering. Continuous blank hammering will not only damage front head and loosen and break bolts, but also adversely affect base machine. Blank hammering Occurs when proper position of the rod is not applied to the breaker or the rod is used as a lever. (Hammering sound changes during blank hammering. )

#### (3) Do not move rocks

Avoid moving rocks with side of the bracket, because it is the major factor to break bolts installed on the bracket, rod and damage boom and arm.

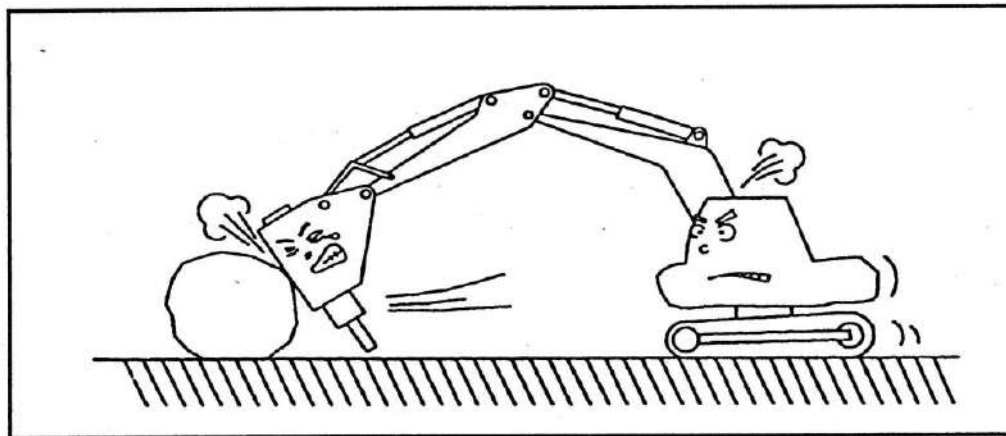
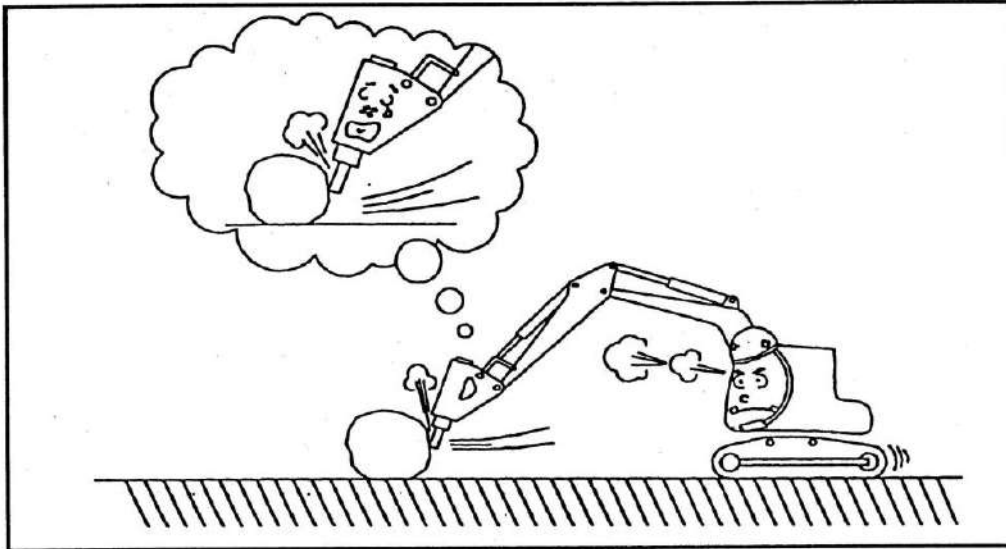

(4) Do not use rod as a lever .

When breaking rocks by using rod as a lever, bolts and rod may be broken .

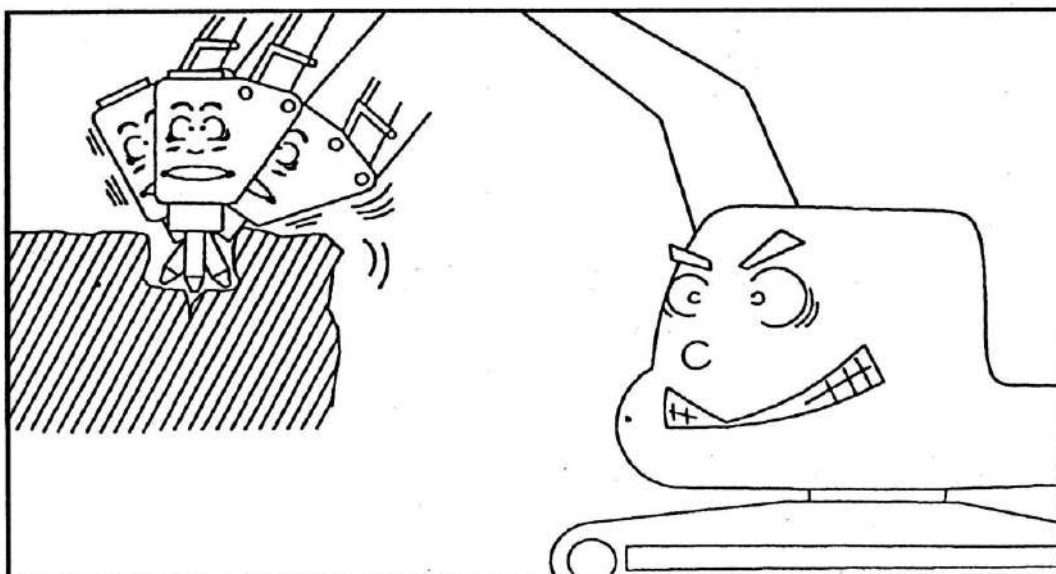

(5) Do not continue to hammer for more than one minute.

When rocks are not broken after more than one minute's hammering at the same point, change the place to be hammered. Extended hammering at the same place causes the rod to wear out excessively.

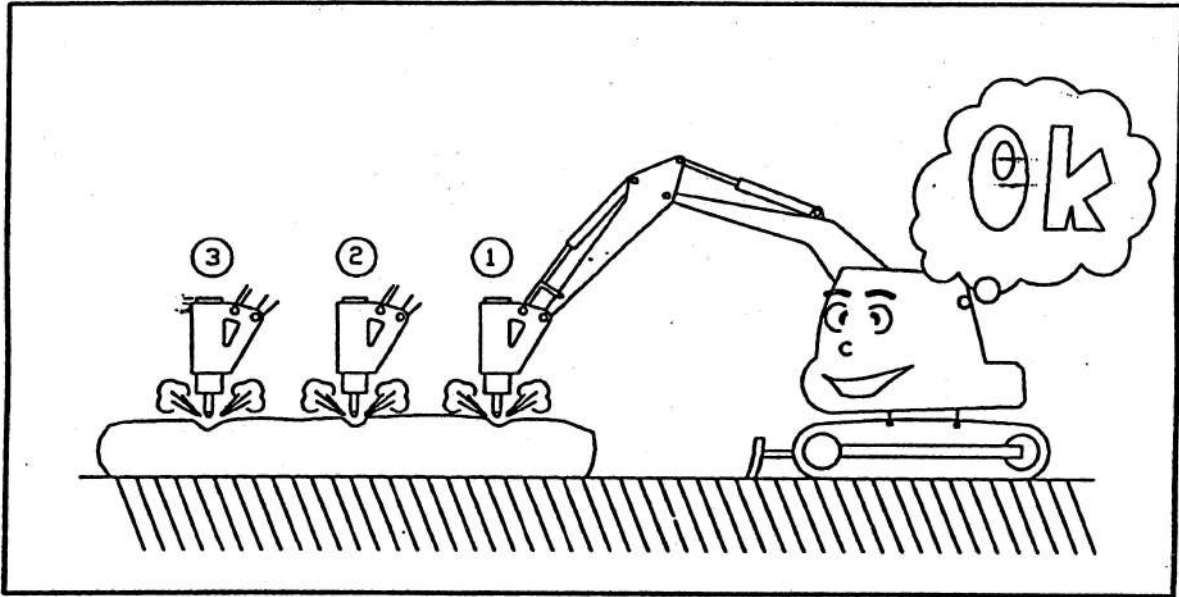

(6) On a hard and large rock, start breaking at an edge.

Even a hard and big rock can be relatively easily broken when hammering begins at a crack or an edge.

(7) Operate breaker at proper engine speed.

Break rocks at the specified engine speed. Raising engine speed more than necessary does not strengthen hammering force but increase oil temperature to the detriment of pistons and valves.

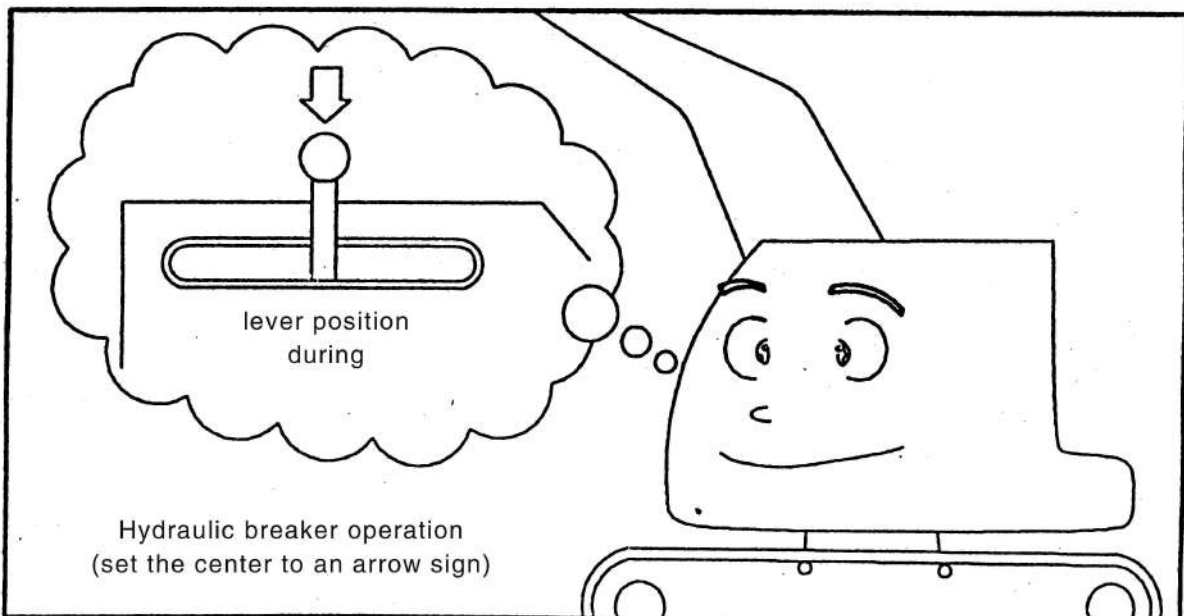

(8) Do not operate the breaker in water and mud .

When rocks are not broken after more than one minute's, do not operate breaker and also do not operate breaker when all components except rod are immersed in water and mud . Piston and similar components may gather rust and become a damaged breaker at an early stage .

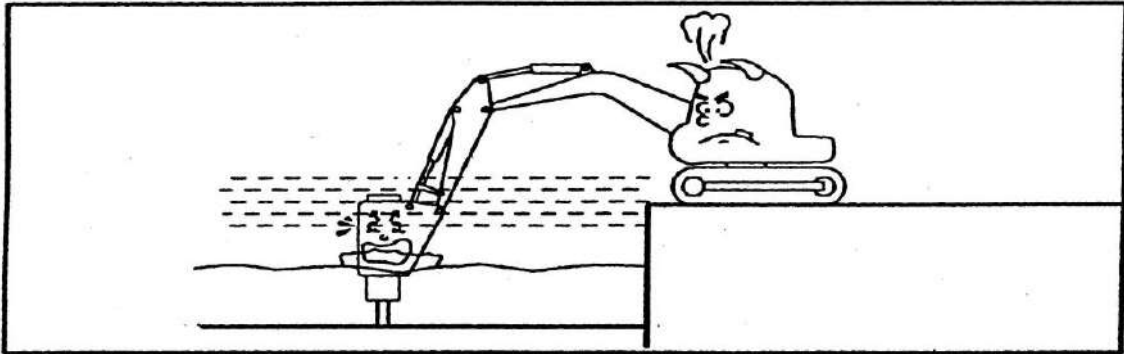

(9) Do not allow the breaker to fall to break a rock .

Falling down the breaker will apply excessive force to the breaker or the base machine , causing damage to many parts of the breaker and the base machine .

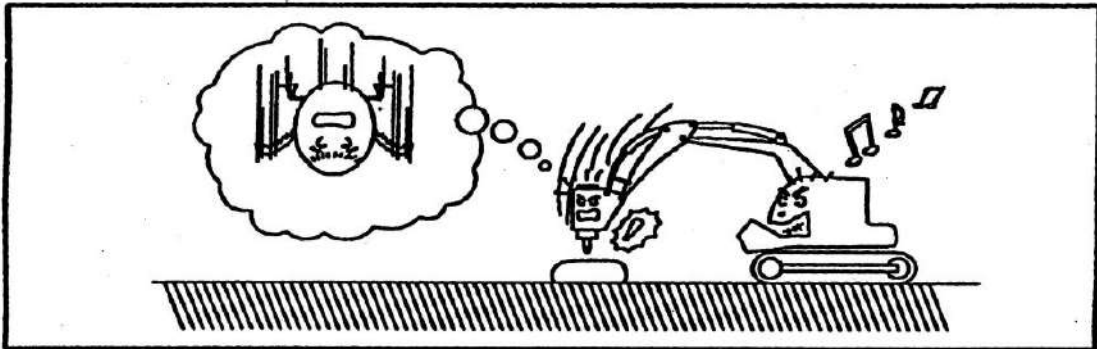

(10) Do not hammer with base machine cylinders moved to stroke end .

Hammering with each base machine cylinder moved to stroke end (a condition that the cylinder is fully extended or retracted) will do considerable damage to the cylinder and each part of the base machine .

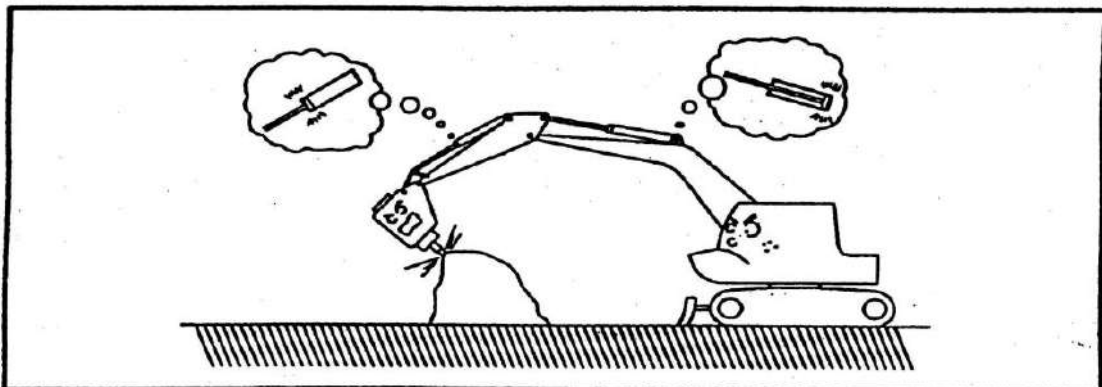

(11) Do not lift things with the breaker.

Lifting materials by hanging wire in the bracket or rod not only causes damage to the breaker but also is very dangerous when operating.

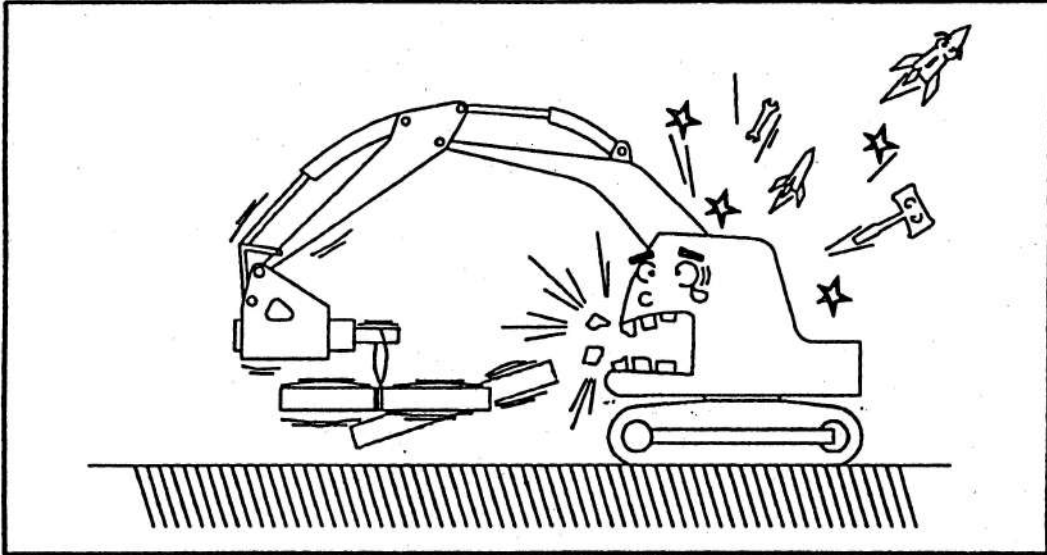

(12) Warm up base machine engine prior to operation.

Especially in winter, the base machine engine should be warmed up for five to ten minutes (30 to 40° C (86 to 105° F)) before breaker operation. Follow the instruction book for base machine for warming-up of the engine.

(13) Do not touch rod when breaker working.

During breaker working, do not touch rod due to high temperature at rod.

(14) When operating the breaker you must use ear protection, eye protection and breathing protection.

(15) Danger of accumulator type.

Attention pressurized container! Do not open the accumulator without reading the manual or consulting the authorized service person!

(16) Greasing

With breaker mounted on carrier, apply down pressure on rod and fill cavity with recommended grease through the grease nipple

(17) Always wear eye protection when removing the stop pin.

Stop pin removed by during it in and out with a punch and hammer.

## 7.Assembly and disassembly of breaker

When the bucket and breaker operation are performed alternately, the bucket and breaker can be easily exchanged by the hydraulic hoses and two pins. There is however, a risk of the hydraulic circuit contamination accordingly, install and remove as below.

- (1) Move the base machine to stable ground free from mud, dust and dirt. Stop the engine, turn off the main switch and deflate air from oil tank if it is pressurized.
- (2) Turn off the shut off valve installed to the end of arm to prevent hydraulic pressure from flowing out.

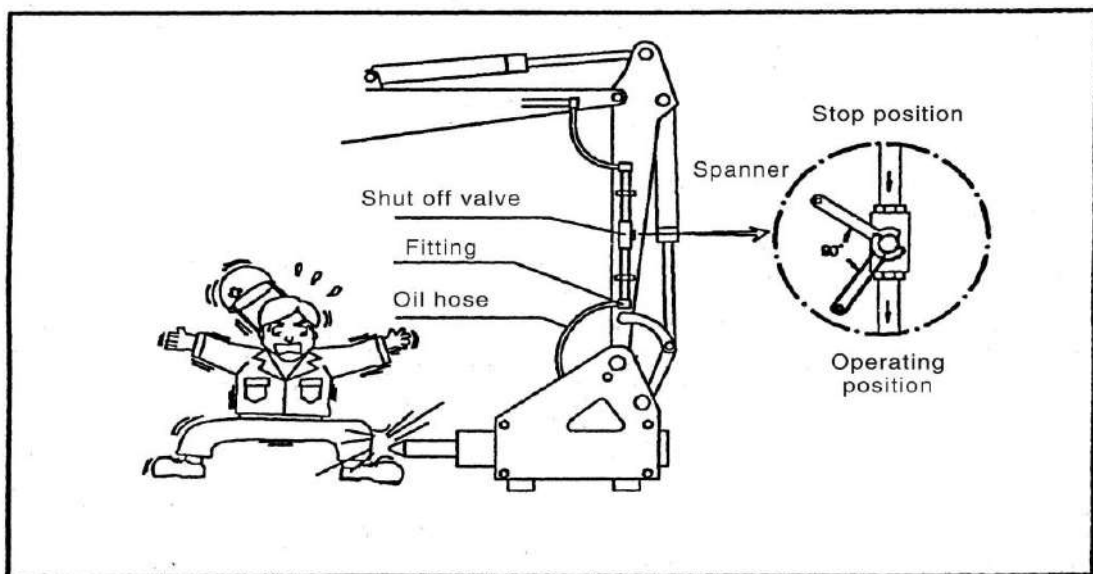

\*Warning !!As rod may fly out due to N<sub>2</sub> gas pressure, do not approach to rod.

- (3) Loosen hose plug on the breaker arm and correct small amount of oil flowing out at this time and put into a container.
- (4) Be careful to prevent mud or dust from entering oil hoses and pipe lines. Plug oil hoses with hose plug and pipe lines with union caps. Bind high and low pressure hoses with a wire to prevent them getting mud.
- (5) To remove the breaker, pull out pins in the bucket link and arm. When leaving the breaker outdoor, set the breaker outdoor, set the breaker on wood blocks and cover with sheets.
- (6) When leaving the breaker removed for a long period of time :
  - Clean exterior of the breaker
  - Remove rod from the front head and spray with rust preventive oil. And bleed N<sub>2</sub> gas from the back head before pushing piston into cylinder.

(7) To install the hydraulic breaker, reverse the aforementioned removal procedures. The bucket operation easily contaminates the end part of hoses and pipe lines. The contaminated part must be cleaned with no delay. Hydraulic oil or light oil is highly recommendable.

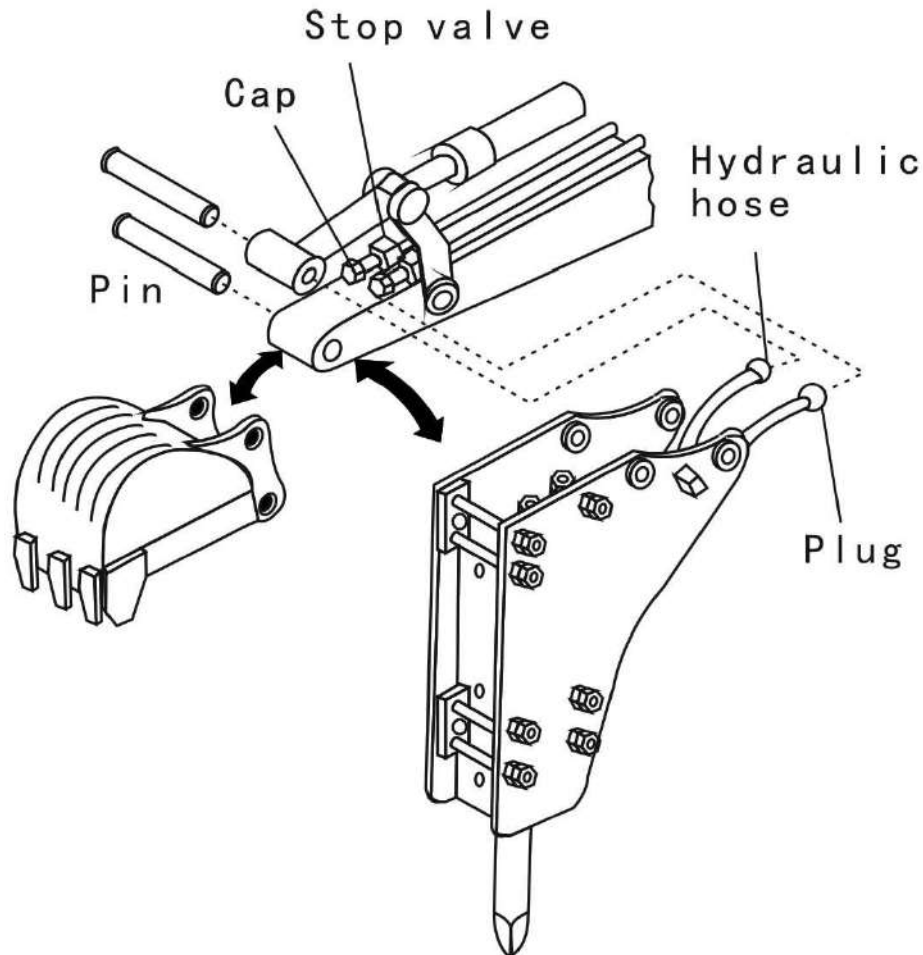

After installation of hydraulic lines for hydraulic breakers:

- (1) Remove the two pins of bucket and take away this bucket.
- (2) Put the arm of excavator into the pinholes of the side bracket and put pins back to the bucket again.
- (3) In case you wish to operate the bucket again, close the stop valve on the excavator's arm and turn the valves off and disconnect the hoses connecting the stop valves to the hydraulic breaker.
- (4) Be sure to blind the disconnected hoses. The entry of sand and mud into the hydraulic hoses and pipes can be a cause for troubles by abrasive friction or rusts, etc.

## 8.Repair and inspection

### 8.1 Maintenance of hydraulic breaker



Inspection period	Inspection items
Detail inspection items before and after the use of breaker	<ul style="list-style-type: none"> <li>● To confirm the installation status of excavator and breaker. Check the abrasion status of pin shaft. Check the installation status of pin shaft's catch bolt. When quick connector is used, check its fixing status and the installation of all round nuts and pin shafts. Check the installations status of bolts of pressing plate and side plate (tower shape)</li> </ul>
	<ul style="list-style-type: none"> <li>● To confirm the assembly status of core and shell of the breaking hammer Check the fastening status of side plate bolts and other bolts. Check the wearing condition of fixing accessories and shock-resisting parts. Check the shell of any cracks or damages and the welding seam.</li> </ul>
	<ul style="list-style-type: none"> <li>● To confirm the status of assembling bolt of breaker core Check all pins, plugs and screws. Check the fastening status of through bolt. Thrust bush, stop pin and rubber plug Stop in and rubber plug Prefabricated air valve Back head air check valve Frequency adjustable valve Fastening bolt of accumulator Fastening bolt of accumulator's cover plate Air check valve of accumulator Hose coupler</li> </ul>
	<ul style="list-style-type: none"> <li>● To confirm the intactness of safety warning signs and labels</li> </ul>
	<ul style="list-style-type: none"> <li>● To confirm the using condition of shell parts Damping washer (low noise) Window cover plate Hose cover plate</li> </ul>
	<ul style="list-style-type: none"> <li>● To check the pipeline of excavator of any friction or oil leakage Check the pipe and hose of any collision or friction. Check the fixing status of valves. Check the welding and fixing status of pipe clamps. Check the pipeline connections of any oil leakage and their assembly status. Check the hose of any bending or aging defects.</li> </ul>
	<ul style="list-style-type: none"> <li>● To confirm the status of oil tank and hydraulic oil Check the amount of hydraulic oil. Check the cleanliness of hydraulic oil.</li> </ul>
	<ul style="list-style-type: none"> <li>● To confirm the status of breaker's switch and the connection of wires</li> </ul>
<ul style="list-style-type: none"> <li>● To visual inspect the abrasion degree of wearing parts Inside diameter of thrust bush Abrasion of rod</li> </ul>	



Inspection period	Inspection items
Items subject to inspection at any time of the operation	<ul style="list-style-type: none"> <li>●Temperature of hydraulic oil (under 80°C)</li> <li>●Falling off or damage of fittings</li> <li>●Oil leakage of breaker and pipeline</li> </ul> <p>Occasionally, there is small amount of oil flowing along the rod (It will cause no influence to the performance, use and operation he breaker.)</p> <p>Any abnormal condition of breaker's efficiency or operation</p> <p>Any irregular striking phenomenon</p> <p>Any abnormal shaking of pipeline</p>
After operation for one hour	<ul style="list-style-type: none"> <li>●Fill in grease (20cc every hour)</li> </ul> <p>Operate the oil gun for 5-10 times</p> <p>Friction surface of rod: inner bush, outer bush, rod pin</p>
Periodic inspection of every week (after 50 hours of running)	<ul style="list-style-type: none"> <li>●Amount and cleanliness of hydraulic oil (supplement and replacement)</li> </ul> <p>Pollution criterion: 20~40cst</p>
	<ul style="list-style-type: none"> <li>●All wearing parts shall be disassembled for inspection (Rectify the deformed parts if necessary)</li> </ul> <p>Rod pin</p> <p>Inner bush</p> <p>Thrust bush</p> <p>Internal cleaning of front head</p> <ul style="list-style-type: none"> <li>●Pressure inspection and supplement of nitrogen</li> </ul> <p>Back head</p> <p>Accumulator</p>
	<ul style="list-style-type: none"> <li>●To confirm the fixing status of bolts and nuts</li> </ul>
Periodic inspection of every month (after 200 hours of running)	<ul style="list-style-type: none"> <li>●Working pressure of breaker</li> <li>●Set pressure of overflow valve of the hydraulic pressure pipeline</li> <li>●Oil consumption</li> <li>●Filter core replacement of excavator</li> </ul>
After three months (after 500-1000 hours of running)	<ul style="list-style-type: none"> <li>●Replacement of oil seal</li> <li>●Replacement of internal leather cup of accumulator</li> <li>●Check the deformation of piston</li> <li>●Check the surface of fittings and grind if necessary</li> </ul>
Long-term keeping for more than one month	<p>Fill in adequate grease.</p> <p>Rod, rod pin, thrust bush, inner bush</p> <p>Apply lubricating oil on surface of piston</p> <p>Emptying of nitrogen</p> <p>Back head</p> <p>Accumulator</p> <p>Re-paint the parts paint off</p>
After completion of underwater operation	Clean and lubricate the core after it is completely dismantled.

Refer to the manufacturer's standard for other maintenance issues related to excavator.

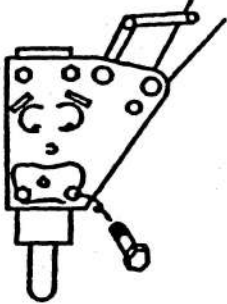
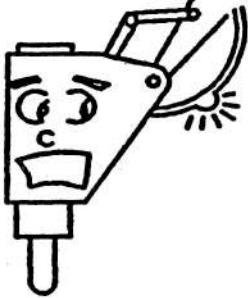
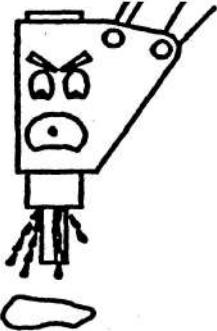
8.2 daily inspection

Before carrying on the work, please inspects each main point in catalogs

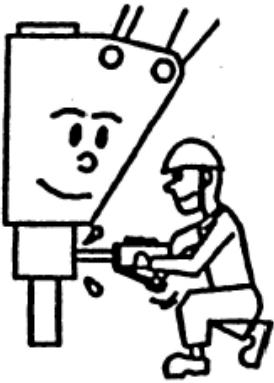
inspection items	inspection points	maintaince way
<p>Loosening or losting of bolt and screw cap</p> 	<p>main body bolt side bracket bolt</p>	<p>Check whether it is loosen Tighten the bol</p>
<p>The hose components become less crowded, hose breakage and oil leakage</p> 	<p>breaker hydraulic pipe line high – pressure Oil pipe</p>	<p>tighten the loosen parts Renovate severy breakage parts</p>
<p>abnormal oil leakage</p> 	<p>The components between back head and cylinder Forebody and rod</p>	<p>please contact local Agents for information in details</p>
<p>abnormal wear and breakage of rod</p> 	<p>rod</p>	<p>renovate or maintain the rod with breakage and wear overused rod can must change at once</p>

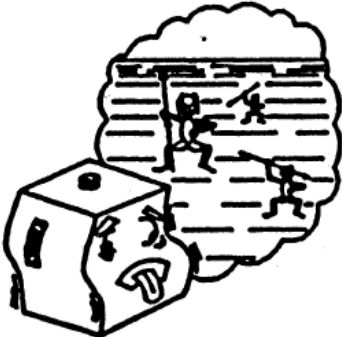
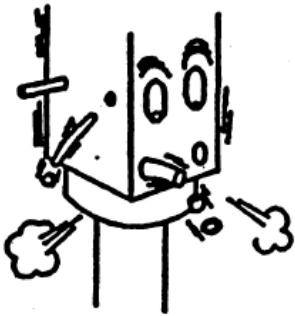
<p>Lubrication</p> 	<p>Apply lubricating oil before every operation and two-three hours after every continuous operation. Infuse 5-10 times.</p>	<p>Infuse from the front head filling orifice.</p> 
<p>Capacity and pollution of hydraulic oil</p> 	<p>Status of hydraulic oil.</p>	<p>Quality of hydraulic oil varies with the working environment. A simple way to judge the quality is to see its color. If the oil becomes inferior seriously, please discharge it from the hydraulic oil tank and clean the tank, then fill in new hydraulic oil.</p>
<p>Missing of rubber plug, pin or other parts</p> 	<p>Rubber plug Stop pin, rod pin, front head pin</p>	<p>Repair immediately to avoid further damages.</p>

### 8.3 Routine inspection and maintenance

Routine is a necessary condition to maintain the best working condition of breaker. We recommend that our customers shall contact our company or dealers within 6 months after the delivery to perform an overall mechanical inspection.

## 8.4 Replacement of rod

Rod shall undergo long term usage. If its top part is worn, it is prone to slide during the running, and must be ground again. However, the repeated grinding and use will spoil the hardened part due to the heat treatment, and thus speed up the deterioration of rod. Under this circumstance, we suggest replacement of rod. If the clearance between rod and thrust bush goes larger, danger may occur due to the non-matching of piston and rod. If the clearance is larger than 9mm, please replace the thrust bush also when you replace the rod.

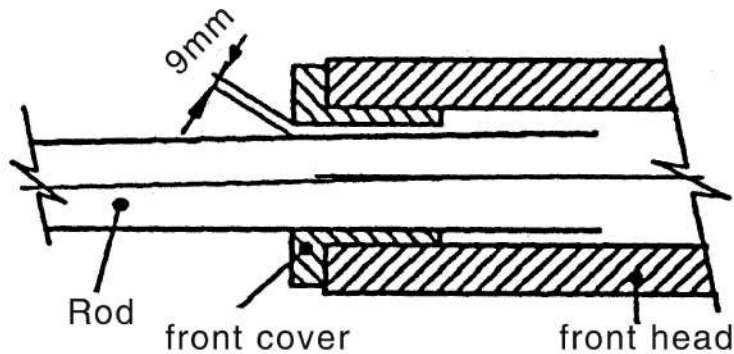

### ■ Precautions of rod replacement

1. To disassemble the rod, push the pin to dismantle the stop pin and rod pin first. To re-assemble it, align the rod pin with the groove on rod, then insert the rod.

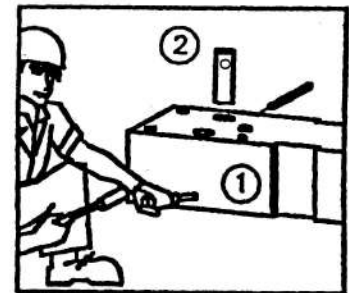

2. Do in the reversed order to install the new rod. Before the installation, please check all parts for spoilage, abrasion or cracks, and remove the attaching on it. Then apply lubricating oil on the friction surface between rod and rod pin. Rod pin seriously damaged will have troubles in the installation. Inspection shall be carried out every 100–150 hours of running.

※ If the rod pin is not the original one supplied by our company, we will not guarantee its working efficiency.

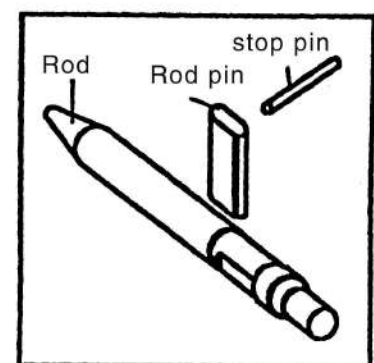

## 8.5 Disassembly and assembly of main body of the breaker.

The main part of breaker is a precision part containing a hydraulic circulating system. It will be very dangerous to dismantle it independently in the factory not well appointed. If it is necessary to disassemble or assemble the breaker, please contact the licensed dealers or agencies, otherwise its mechanical quality and performance will not be within our scope of guarantee.

9 Wearing range of spare parts

9.1 Thrust Bush/Front Cover

Unit : mm

Model	Inner diameter of new parts	Inner diameter of waste parts
NS40	40	42
NS45	45	47
NS53	53	55
NS68	68	71
NS75	75	79
NS100	100	105
NS135A	135	140
NS140A	140	146
NS155	155	161
NS165	165	171
NS175	175	181
NS185	185	191
NS190	190	196
NS195	195	201

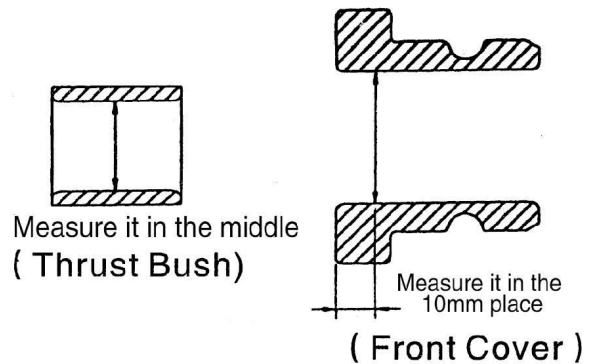

9.2 Ring Bush

Unit : mm

Model	Inner diameter of new parts	Inner diameter of waste parts	New Parts	Waste parts
NS40	40	42	8.75	7
NS45	45	47	12.25	8
NS53	53	55	8.5	6
NS68	68	71	10.5	7.5
NS75	75	79	15	12
NS100	100	105	17	14
NS135A	135	140	32.5	29.5
NS140A	140	146	40	37
NS155	155	161	46	43
NS165	165	171	41	38
NS175	175	181	53.5	50.5
NS185	185	191	45	42
NS190	190	196	31.5	28.5
NS195	195	201	45	42

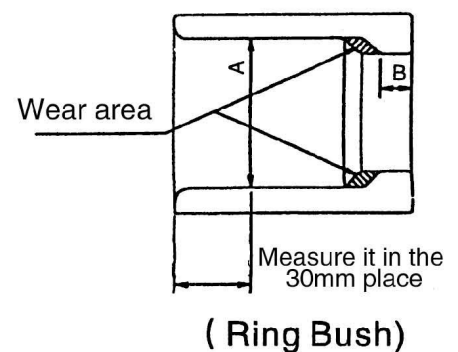

9.3 Rod Pin

Unit : mm

Model	New Parts	Waste parts
NS40	28	26
NS45	28	26
NS53	32	30
NS68	38	36
NS75	42	40
NS100	60	57
NS135A	82	79
NS140A	88.5	85.5
NS155	96	93
NS165	96	93
NS175	99	95
NS185	121	118
NS190	110	107
NS195	121	118

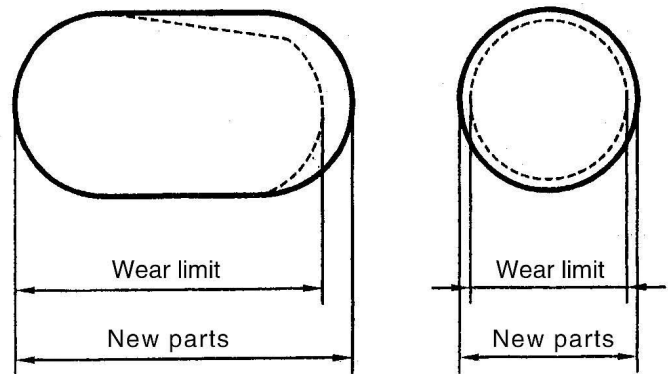

(Rod Pin)

9.4 Stop Pin

Unit : mm

Model	Inner diameter of new parts	Inner diameter of waste parts
NS40	13	11
NS45	13	11
NS53	13	11
NS68	16	14
NS75	16	14
NS100	17.5	15.5
NS135A	17.5	15.5
NS140A	20	18
NS155	17.5	15.5
NS165	17.5	15.5
NS175	18	16
NS185	26	24
NS190	26	24
NS195	26	24

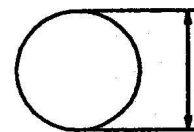

(Stop Pin)

## 9.5 Front Head Pin

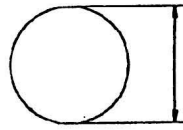

( Front Head Pin )

Unit : mm

Model	Inner diameter of new parts	Inner diameter of waste parts
NS100	26	24
NS135A	30	24
NS140A	26	28
NS155	26	24
NS165	26	24
NS175	36	34
NS185	36	34
NS190	36	34
NS195	36	34

**10. Inspection and filling of back head nitrogen (see the next page for the detail drawing)****10.1 Test the pressure of back head nitrogen**

- (1) Tightly wind up the three-way valve (5) and its cap joint. Take out the socket plug on the back head air check valve, and wind up the three-way valve (5) with the air check valve.
- (2) The handle of the three-way valve (5) must be standing upright to avoid air leakage.
- (3) Force down the standing handle. At this time, the pressure of back head air is indicated on the pressure meter.
- (4) If the pressure is within the normal range, exhaust the air inside the three-way valve, then unscrew it.
- (5) If the pressure is too high or low, adjust it according to the instructions in the following.

**10.2 Fill in the back head nitrogen**

- (1) Tight adaptor (3) and round nut (2), and install them on the nitrogen bottle. Wind up gas-filled tube (4) to the nitrogen bottle.
- (2) Unscrew the cap joint on the three-way valve, and connect the gas-filled tube (4) with the three-way valve (5).
- (3) Install the three-way valve (5) onto the back head air check valve. At this time, the handle of three-way valve must be standing upright to avoid nitrogen leakage.
- (4) Force down the standing handle completely. Slowly turn the handle of nitrogen bottle counterclockwise to fill in gas.
- (5) Immediately turn the handle clockwise when nitrogen pressure exceeds 10% of the set value to shut the nitrogen bottle.
- (6) Move hand away from the handle of three-way valve. Pressure of the nitrogen room will restore the handle to the upright position before the gas filling.
- (7) Turn the vent valve on the three-way valve counterclockwise, so as to discharge the nitrogen inside the gas-filled tube (4) and the three-way valve (5).
- (8) Dismantle the gas-filled tube (4) from the nitrogen bottle (1) and the three-way valve (5). Wind up the union nut on the three-way valve.
- (9) Force down the upright handle of the three-way valve, then the back head nitrogen pressure shall display within the set values. If the pressure is too high, open and close the vent valve repeatedly to release some nitrogen till the pressure reduces to normal.
- (10) When nitrogen pressure reaches to the set valve, loosen the handle and shut the three-way valve.
- (11) Completely open the vent valve to discharge nitrogen in the three-way valve. Dismantle the three-way valve from the air check valve, and install socket plug on it. Prevent the coming of any foreign substances into the breaker.

The pressure meter for nitrogen filling at the back head  
(decided by the surface temperature of the back head)

	Unit	NS 40	NS 45	NS 53	NS 68	NS 75	NS 85	NS 100	NS 120	NS 135A	NS 140A	NS 155	NS 165	NS 175	NS 185	NS 190	NS 195
Nitrogen gas of Back Head	BAR	12	12	12	12	12	16	16	6	5	16	18	18	18	22	23	24

### 10.3 N2 Gas Charging Tools to Back Head

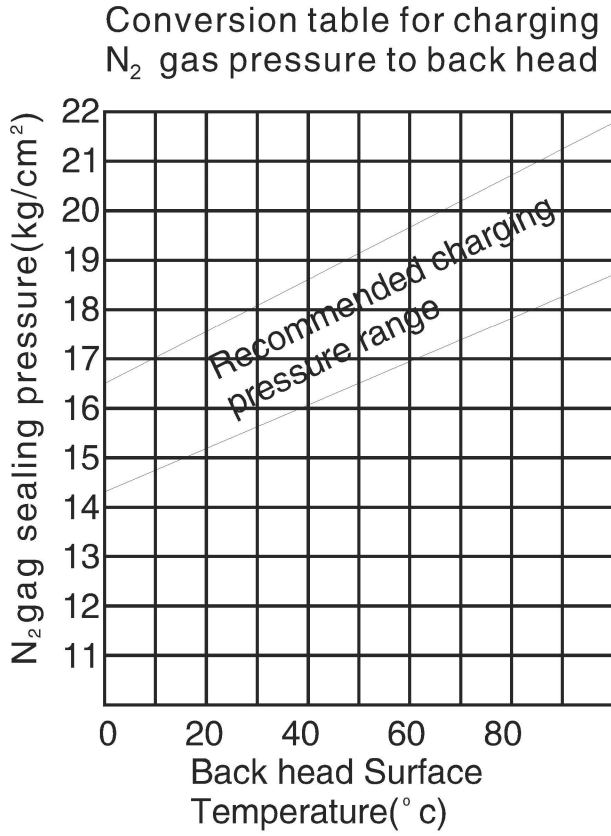
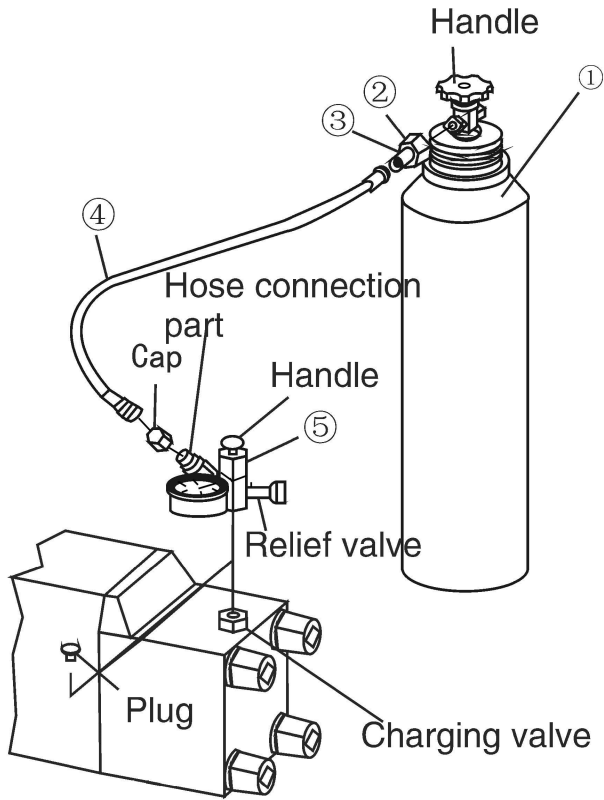

No	Part Name	Q'ty	Remarks
①	N2 gas Cylinder	1	
②	Bombe Adaptor Nut	1	
③	Bombe Adaptor	1	
④	Synflex Hose	1	
⑤	3 Way Valve Assembly	1	

**11. Inspection and filling of accumulator nitrogen (see the next page for the detail drawing)****11.1 Check the nitrogen pressure of the accumulator.**

1. Completely tighten the three-way valve (5) and its cap joint.
2. Take off the cap joint (11) from the accumulator, and completely tighten the air check valve (12).
3. Check whether O-rings (6) (8) are on the adapter (7) or not. Dismantle the plug (9) and wind up the adapter (7).
4. Install the three-way valve on the adapter (7).
5. Slowly loosen the air check valve (12). Pressure of gas filling will be displayed on the pressure meter.
6. If the nitrogen pressure is normal, shut the air check valve (12) by turning clockwise. If the pressure is too large, loosen and wind up the vent valve on the three-way valve repeatedly, so as to decrease the nitrogen pressure gradually.
7. Loosen the vent valve to discharge the nitrogen in the three-way valve.
8. Dismantle the three-way valve (5) and wind up the plug (9) and cap joint (11).

**11.2 Nitrogen filling into the accumulator**

1. Fasten the joint (2) and coupling nut (3), and install them onto the nitrogen bottle. Then connect the gas-filled tube (4) to the nitrogen bottle (1).
2. Unscrew the cap joint on the three-way valve, and connect the gas-filled tube (4) and the three-way valve.
3. Dismantle the cap joint (11) from the accumulator, and completely wind up the air check valve (12).
4. Check whether O-rings (6) (8) are on the adapter (7) or not. Dismantle the plug (9) and wind up the adapter (7).
5. Install the three-way valve on the adapter (7). Loosen the air check valve (12) on the accumulator.
6. Slowly turn the valve of nitrogen bottle counterclockwise to fill in nitrogen.
7. The pressure of gas filling must be in consistent with the data in the accumulator's gas filling pressure list.
8. Turn off the valve of nitrogen bottle clockwise.
9. Shut the air check valve (12) of the accumulator.
10. Unscrew the outflow valve on the three-way valve to discharge the remaining nitrogen in the gas-filled tube.
11. Dismantle the gas-filled valve, three-way valve and adapter (7), and wind up the plug (9) and cap joint (11).

The pressure meter for nitrogen filling of the accumulator  
(decided by the surface temperature of the accumulator)

Charging Pressure of Accumulator	Surface Temperature of Accumulator (° C/° F)				
	0/32	10/50	20/68	30/86	40/104
kg/cm <sup>2</sup>	51.2	53.1	55	56.8	58.7
psi	730	755	780	815	830

### 11.3 N2 Gas Charging Tools to Back Head

NO	Part Name	Q'ty	Remarks
①	N <sub>2</sub> Gas Cylinder	1	
②	Bombe Adaptor Nut	1	
③	Bombe Adaptor	1	
④	Synflex Hose	1	
⑤	3 Way Valve Assembly	1	
⑥	O-Ring	1	
⑦	Hex Bushing	1	
⑧	O-Ring	1	
⑨	Plug	1	
⑩	O-Ring	2	
⑪	Cap	1	
⑫	Accumulator Charging Valve	1	
⑬	O-Ring	1	

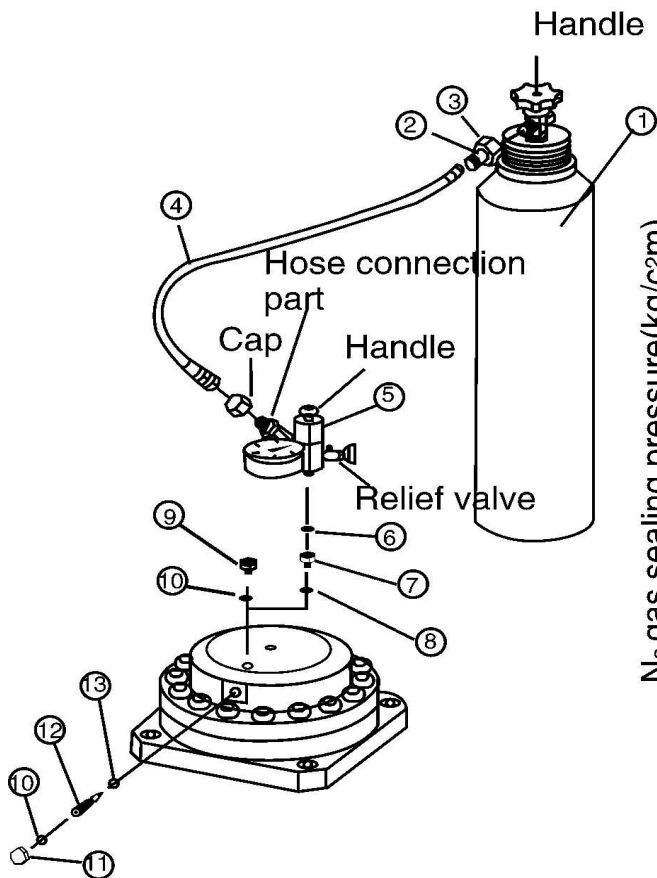

Conversion table for charging N<sub>2</sub> gas pressure to accumulator

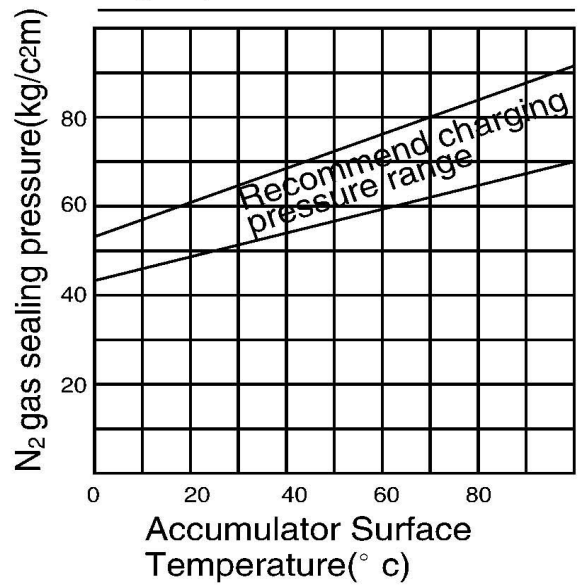

**(Precautions on nitrogen utilization)**

1. The nitrogen bottle is filled with high-pressure gas. Special care shall be taken during the storage and use.
2. No other gas than nitrogen could be filled in.

**(Precautions of nitrogen filling)**

1. Pressure of filling nitrogen varies with the rod condition. During the filling, the breaker must be placed flat and level.
2. Do not approach the rods during nitrogen filling.

(Sometimes rod will bounce out due to the high pressure of nitrogen.)

3. To replace the main bolts or to disassemble the main body, please confirm that nitrogen has been completely discharged.

## 12. Troubleshooting table

This table will help users to find out causes in case of breaker faults, and communicate with maintenance personnel to get a proper resolution.

Conditions or problems	Cause	Countermeasure
1. Breaker does not work. (1) Hydraulic oil has not flowed into the breaker. (2) Hydraulic oil has flowed into the breaker.	(a) Hose or oil channel does not function. Oil channel is blocked or the pipeline is damaged. (b) Control valve or relevant parts are damaged. (c) Hydraulic oil is insufficient. (d) Parts of breaker are damaged.	(a) Check, clean and repair the hydraulic oil pipeline. Replace if necessary. (b) Check the valve and relevant parts. Replace if necessary. (c) Fill up the hydraulic oil tank. (d) Contact dealers or maintenance personnel.
2. Striking force is weakened. (1) Hydraulic oil has not flowed into the breaker. (2) Hydraulic oil has flowed into the breaker.	(a) Oil tube or hose does not function. •Oil channel is blocked. •Oil is leaking. (b) Control valve or relevant parts are damaged. •Deformed pedal •Deformed control valve •Scratched control valve •Malfunction of control valve due to loosening of screws (c) The return pipe of mechanical oil tank is blocked. (d) Hydraulic oil is insufficient. (e) Hydraulic oil is deteriorated or polluted. (f) Oil pressure auxiliary equipment does not function well. (g) Breaker has foreign matter inside. (h) Back head nitrogen pressure is insufficient.	(a) Check, clean and repair the pipeline. Replace if necessary. (b) Check the valve and relevant parts. Replace if necessary. (c) Clean or replace. (d) Fill in hydraulic oil. (e) Clean the storage tank and renew the hydraulic oil. (f) Ask the engineering mechanical service company to inspect the machine. (g) Please contact our dealers. (h) Please adjust the pressure of nitrogen.
3. Striking force decreases suddenly; the high pressure end of the hydraulic pipe shakes violently.	(a) Nitrogen leaks due to back head failure.	(a) Contact our agencies for repair.
4. Rod or front head is leaking oil.	(a) Piston oil is exhausted.	(a) Contact our agencies for repair.
5. Piston moves but not strikes.	(a) Rod is broken.	(a) Disassemble the front head, take out the rod and repair.

For faults of engineering mechanical parts, please contact the engineering mechanical company for repair.

### 13. Hydraulic oil

#### 13.1 Selection of hydraulic oil

Quality of hydraulic oil decides the efficiency of the breaker. In case of any of following conditions, please contact our authorized agencies or dealers.

- (1) The machine must be operated under special weather conditions (such as in extremely cold or hot areas).
- (2) The recommended hydraulic oil can not be achieved, and other hydraulic oil should be used as a substitute.
- (3) The hydraulic oil recommended by the engineering machines is not ideal for the breaker.

#### Hydraulic oil and lubricating oil for Nuosen Company' s Recommendations

Manufacturer	Oil for summer use	Oil for winter use	Lubricating oil (NLTGI.NO)
Shell	Shell Tellus T68	Shell Tellus T46	Alvania Grease2
ESSO	Nuto H68	Nuto H46	Beacon Q2
Mobil	Mobil DTE 16	Mobil DTE 15	Mobil Grease Special
Gulf	Harmony 68	Harmony 46	Gulf Grown EP2
Caltex	Lando CZ68	Lando CZ46	.....

#### 13.2 Oil pollution

The use of polluted hydraulic oil will damage the breaker and the engineering mechanical body and parts. Therefore the oil quality shall be rendered special attention. Once the hydraulic oil is polluted or deteriorated, renew it immediately. Before the renewal, clean the oil tank, pump and pipeline thoroughly. If the oil quality becomes worse, inspect and clean the filter cleaner also, or replace it if necessary.

Replacement of filter cleaner: First time of replacement shall take place after 50 hours of running. Subsequent replacements shall be carried out every 100 service hours.

Renew of hydraulic oil: Every 600 service hours.

# HYDRAULIC BREAKER

## PARTS LIST

### CONTENTS

Parts And Accessories List.....	40
NS40,NS45,NS53,NS68,NS75.....	40
NS85,NS100.....	42
NS140A,NS155,NS165,NS175.....	44
NS120,NS135A.....	47
NS185.....	50
NS190.....	53
NS195.....	56
Case Parts Accessories List.....	59
Side Type.....	59
Top Type.....	63
Box Type.....	67
Tools and Tools Box.....	70
Back Head Gas Charging Kit(Optional).....	72
Accumulator Charging Tool Set.....	73

Parts and accessories list (NS40-NS75)

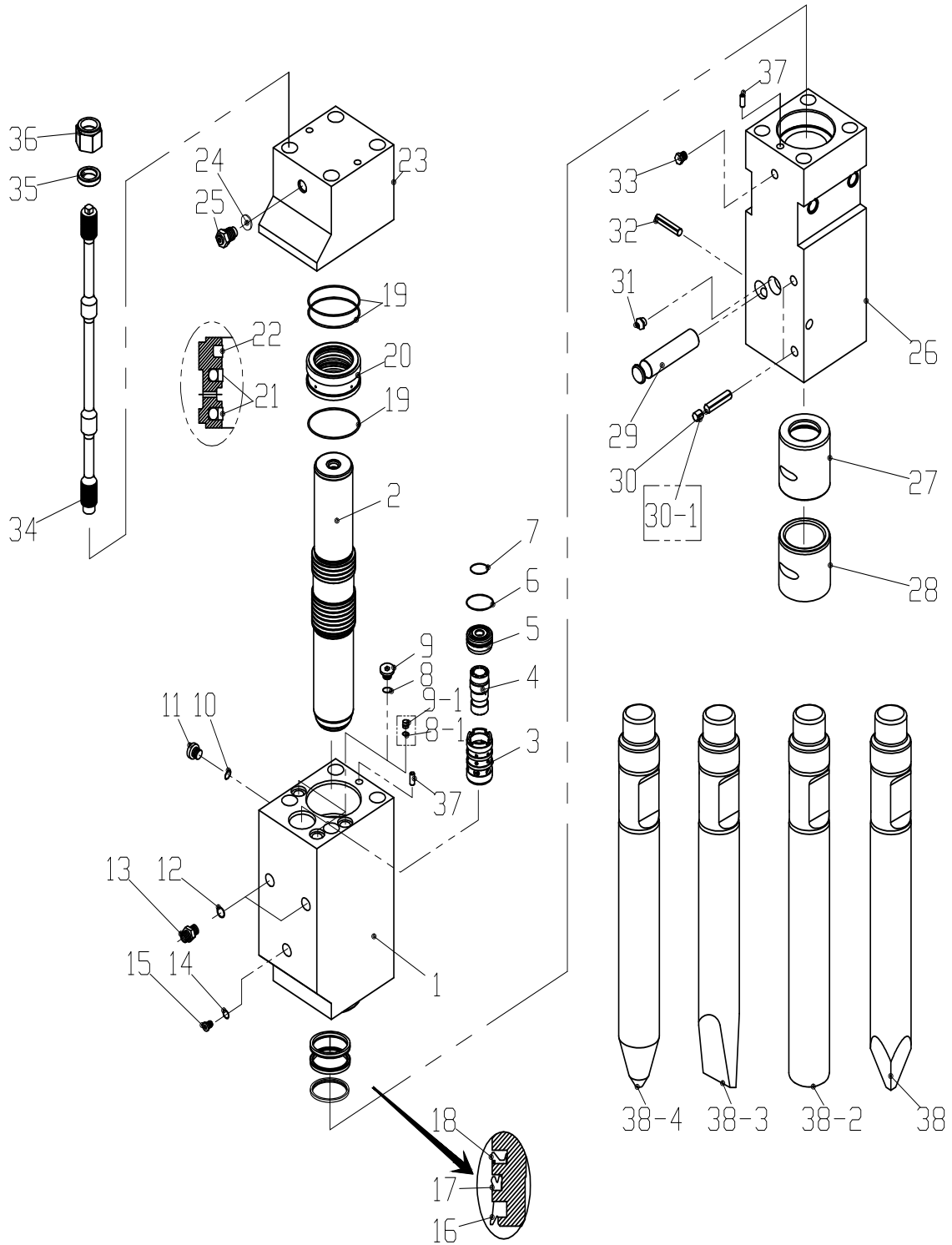

MAIN BODY (RWB40-RWB75)

NO	PARTS NAME	NS40		NS45		NS53		NS68		NS75		Remark
		P/N	Qty	P/N	Qty	P/N	Qty	P/N	Qty	P/N	Qty	
1	Cylinder	S3031001	1	S3041001	1	S3061001	1	S3071001	1	S3081001	1	
2	Piston	S3031002	1	S3041002	1	S3061002	1	S3071002	1	S3081002	1	
	<b>Valve Assy's</b>	S5031000	/	S5041000	/	S5061000	/	S5071000	/	S5081000	/	
3	Valve Sleeve	S5031002	1	S5031002	1	S5061002	1	S5071002	1	S5081002	1	
4	Valve	S5031003	1	S5031003	1	S5061003	1	S5071003	1	S5081003	1	
5	Valve Plug	S5031004	1	S5031004	1	S5061004	1	S5071004	1	S5081004	1	
6	O-Ring	B2002030	1	B2002030	1	B2002032	1	B2001040	1	B2001040	1	
7	O-Ring	B2001025	1	B2001025	1	B2001025	1	B2001030	1	B2001030	1	
8	O-Ring	/	/	/	/	/	/	B2002016	3	B2002016	3	
9	Plug	/	/	/	/	/	/	B7001018	3	B7001018	3	
8-1	O-Ring	B2002011	3	B2002011	3	B2002011	3	/	/	/	/	
9-1	Plug	B7001315	3	B7001315	3	B7001315	3	/	/	/	/	
10	O-Ring	/	/	/	/	/	/	B2002018	1	B2002018	1	
11	Plug	/	/	/	/	/	/	B7001021	1	B7001021	1	
12	O-Ring	B2002018	2	B2002018	2	B2002018	2	B2002018	2	B2002018	2	
13	Adapter	B7002021	2	B7002021	2	B7002021	2	B7002021	2	B7002021	2	
14	O-Ring	B2002016	1	B2002018	1	B2002018	1	/	/	/	/	
15	Plug	B7001018	1	B7001021	1	B7001026	1	/	/	/	/	
	<b>Seal Kit</b>	B2031000	/	B2041000	/	B2061000	/	B2071000	/	B2081000	/	
16	Dust Seal	B2031001	1	B2041001	1	B2061001	1	B2071001	1	B2081001	1	
17	U-Packing	B2031002	1	B2041002	1	B2061002	1	B2071002	1	B2081002	1	
18	Buffer Seal	/	/	/	/	/	/	/	/	B2081003	1	
19	O-Ring	B2001060	3	B2001065	3	B2001070	3	B2001092	4	B2001100	4	
21	Step Seal	B2031007	2	B2041007	2	B2061007	2	B2071007	2	B2081007	2	
22	Gas Seal	B2031008	1	B2041008	1	B2061008	1	B2071008	1	B2081008	1	
20	Seal Retainer	S3031004	1	S3041004	1	S3061004	1	S3071004	1	S3081004	1	
23	Back Head	S4031001	1	S4041001	1	S4061001	1	S4071001	1	S4081001	1	
24	O-Ring	B2002018	1	B2002018	1	B2002018	1	B2002018	1	B2002018	1	
25	Charging Valve	B7003021	1	B7003021	1	B7003021	1	B7003021	1	B7003021	1	
26	Front Head	S2031001	1	S2041001	1	S2061001	1	S2071001	1	S2081001	1	
27	Thrust Bush	S2031003	1	S2041003	1	S2061003	1	S2071003	1	S2081003	1	
28	Front Bush	S2031002	1	S2041002	1	S2061002	1	S2071002	1	S2081002	1	
29	Rod Pin	S2031004	1	S2041004	1	S2061004	1	S2071004	1	S2081004	1	
30	Spring Pin/Front Cover Pin	S2031005	2	S2041005	2	S2061005	2	S2071005	2	S2081005	2	
30-1	Spring Pin	B7007313	2	B7007313	2	B7007313	2	/	/	/	/	
31	Grease Nipple	B7005001	1	B7005001	1	B7005001	1	B7005001	1	B7005001	1	
32	Stop Pin	B7007210	1	B7007210	1	B7007210	1	B7007210	1	B7007210	1	
33	Air Check Valve	B7004021	1	B7004021	1	B7004021	1	/	/	B7004021	1	
	<b>Through Bolt Assy's</b>	S8031000	/	S8041000	/	S8061000	/	S8071000	/	S8081000	/	
34	Through Bolt	S8031001	4	S8041001	4	S8061001	4	S8071001	4	S8081001	4	
35	Washer	S8031004	4	S8041004	4	S8061004	4	S8071004	4	S8081004	4	
36	Hex Nut	S8031003	4	S8041003	4	S8061003	4	S8071003	4	S8081003	4	
37	Locked Pin	/	/	/	/	/	/	B7007112	2	B7007112	2	
38	Rod(Moil Point)	B1033000	1	B1043000	1	B1063000	1	B1073000	1	B1083000	1	
38-2	Rod(Blunt)	B1032000		B1042000		B1062000		B1072000		B1082000		
38-3	Rod(Wedge)	B1034000		B1044000		B1064000		B1074000		B1084000		
38-4	Rod(Cone)	B1031000		B1041000		B1061000		B1071000		B1081000		

Parts and accessories list (NS85,NS100)

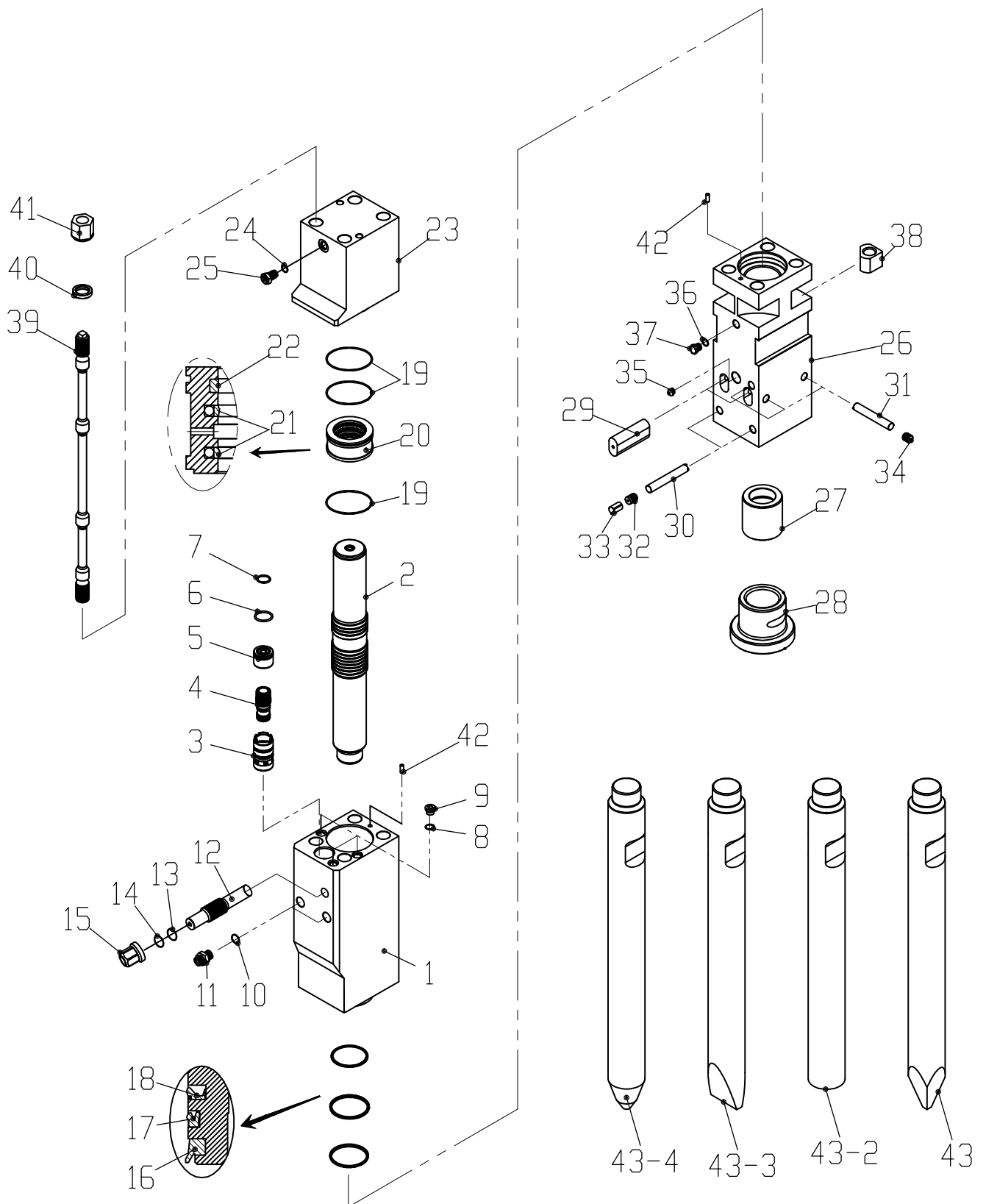

## MAIN BODY(NS85,NS100)

NO	PARTS NAME	NS85		NS100		Remark
		P/N	Qty	P/N	Qty	
1	Cylinder	S3091001	1	S3111001	1	
2	Piston	S3091002	1	S3111002	1	
	<b>Valve Assy's</b>	S5091000	/	S5111000	/	
3	Valve Sleeve	S5091002	1	S5111002	1	
4	Valve	S5091003	1	S5111003	1	
5	Valve Plug	S5091004	1	S5111004	1	
6	O-Ring	B2001045	1	B2002052	1	
7	O-Ring	B2001030	1	B2001035	1	
8	O-Ring	B2002018	3	B2002022	3	
9	Plug	B7001021	3	B7001026	3	
10	O-Ring	B2002024	2	B2002024	2	
11	Adapter	B7002026	2	B7002026	2	
12	Valve Adjuster	/	/	/	/	
13	O-Ring	/	/	/	/	
14	O-Ring	/	/	/	/	
15	Nuts For Valve Adjuster	/	/	/	/	
	<b>Seal Kit</b>	S2091000	/	B2111000	/	
16	Dust Seal	B2091001	1	B2111001	1	
17	U-Packing	B2091002	1	B2111002	1	
18	Buffer Seal	B2091003	1	B2111003	1	
19	O-Ring	B2001115	3	B2001135	4	
21	Step Seal	B2091007	2	B2111007	2	
22	Gas Seal	B2091008	1	B2111008	1	
20	Seal Retainer	S3091004	1	S3111004	1	
23	Back Head	S4091001	1	S4111001	1	
24	O-Ring	B2002018	1	B2002018	1	
25	Charging Valve	B7003021	1	B7003021	1	
26	Front Head	S2091001	1	S2111001	1	
27	Thrust Bush	S2091003	1	S2111003	1	
28	Front Bush	S2091002	1	S2111002	1	
29	Rod Pin	S2091004	2	S2111004	2	
30	Front Cover Pin	S2091005	2	S2111005	2	
31	Spring Pin/Stop Pin	S2091006	3	S2111006	3	
32	Rubber For Front Cover Pin	B7007317	2	B7007326	2	
33	Spring Pin	/	2	B7007226	2	
34	Rubber For Spring Pin/Stop Pin	B7007317	3	B7007318	3	
35	Grease Nipple	B7005001	1	B7005001	1	
36	O-Ring	B2002018	1	B2002018	1	
37	Air Check Valve	B7004021	1	B7004021	1	
38	Nuts For Through Bolt	S8091102	4	S8111002	4	
	<b>Through Bolt Assy's</b>	S8091000	/	S8111000	/	
39	Through Bolt	S8091001	4	S8111001	4	
40	Washer	S8091004	4	S8111004	4	
41	Hex Nut	S8091003	4	S8111003	4	
42	Locked Pin	B7007112	2	B7007112	2	
43	Rod (Moil Point)	B1093000	1	B1113000	1	
43-2	Rod (Blunt)	B1092000		B1112000		
43-3	Rod (Wedge)	B1094000		B1114000		
44-4	Rod (Cone)	B1091000		B1111000		

Parts and accessories list ( NS140A, NS155, NS165, NS175)

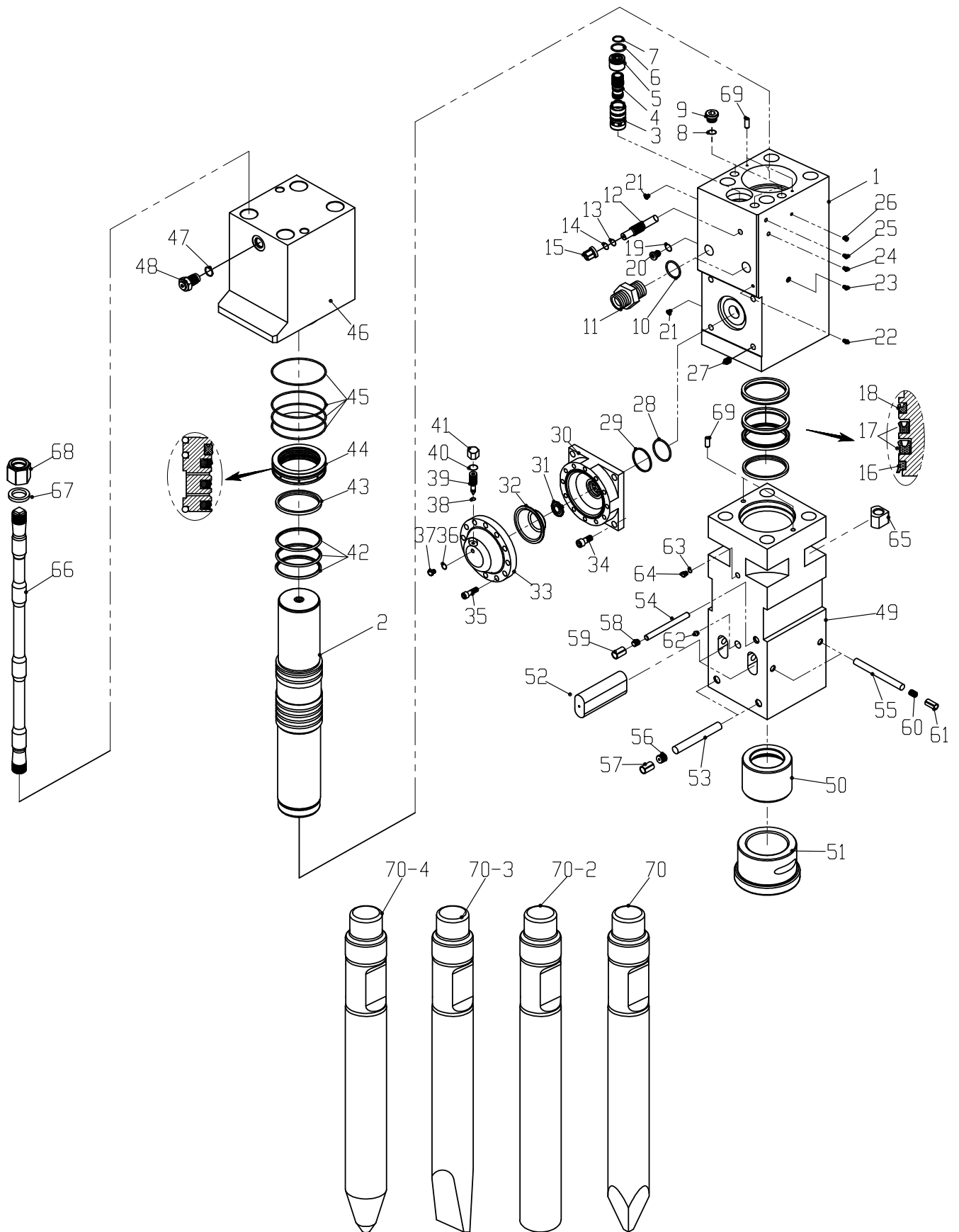

**MAIN BODY(NS140A,NS155,NS165,NS175)**

NO	PARTS NAME	NS140A		NS155		NS165		NS175		Remark
		P/N	Qty	P/N	Qty	P/N	Qty	P/N	Qty	
1	Cylinder	S3151001	1	S3221001	1	S3231001	1	S3251001	1	
2	Piston	S3141002	1	S3221002	1	S3231002	1	S3251002	1	
	<b>Valve Assy's</b>	S5151000	/	S5221000	/	S5231000	/	S5251000	/	
3	Valve Sleeve	S5141002	1	S5221002	1	S5231002	1	S5251002	1	
4	Valve	S5141003	1	S5221003	1	S5231003	1	S5251003	1	
5	Valve Plug	S5141004	1	S5221004	1	S5231004	1	S5251004	1	
6	O-Ring	B2001070	1	B2001085	1	B2001080	1	B2001100	1	
7	O-Ring	B2001055	1	B2001055	1	B2001055	1	B2001080	1	
8	O-Ring	B2002025	3	B2002032	3	B2002032	3	B2002035	3	
9	Plug	B7001027	3	B7001036	3	B7001036	3	B7001039	3	
10	O-Ring	B2002038	2	B2002044	2	B2002044	2	B2002044	2	
11	Adapter	B7002042	2	B7002049	2	B7002049	2	B7002049	2	
12	Valve Adjuster	B8141101	1	B8221101	1	B8221101	1	B8251101	1	
13	O-Ring	B2002022	1	B2002029	1	B2002029	1	B2002029	1	
14	O-Ring	B2002015	1	B2002018	1	B2002018	1	B2002018	1	
15	Nuts For Valve Adjuster	B8141102	1	B8221102	1	B8221102	1	B8251102	1	
	<b>Seal Kit</b>	B2151000	/	B2221000	/	B2231000	/	B2251000	/	
16	Dust Seal	B2141001	1	B2221001	1	B2231001	1	B2251001	1	
17	U-Packing	B2141002	1	B2221002	1	B2231002	2	B2251002	2	
18	Buffer Seal	B2141003	1	B2221003	1	B2231003	1	B2251003	1	
42	Step Seal	B2141007	2	B2221007	2	B2231007	3	B2251007	3	
43	Gas Seal	B2141008	1	B2221008	1	B2231008	1	B2251008	1	
45	O-Ring	B2001180	3	B2001195	3	B2001210	3	B2001210	4	
44	Seal Retainer	S3141004	1	S3221004	1	S3231004	1	S3251004	1	
19	O-Ring	/	/	/	/	B2002032	1	B2002035	3	
20	Plug	/	/	/	/	B7001036	1	B7001039	3	
21	Plug	/	/	/	/	B7001113	2	B7001118	2	
22	Plug	/	/	/	/	B7001113	1	B7001113	1	
23	Plug	/	/	/	/	B7001113	1	B7001113	1	
24	Plug	/	/	/	/	B7001118	1	B7001118	1	
25	Plug	/	/	/	/	B7001113	1	B7001118	1	
26	Plug	/	/	/	/	B7001113	1	B7001113	1	
27	Sleeve For Bolt	B7006024	4	B7006024	4	B7006024	4	B7006024	4	
	<b>Accumulator Assy's</b>	S6151000	/	S6221000	/	S6231000	/	S6251000	/	
28	Rings For Shoulder	B2003080	1	B2004095	1	B2004095	1	B2003080	1	
29	O-Ring	B2001080	1	B2002095	1	B2002095	1	B2001080	1	
30	Accumulator Body	S6141002	1	S6221002	1	S6221002	1	S6251002	1	
31	Hodler	S6141004	1	S6141004	1	S6141004	1	S6141004	1	
32	Diaphragm	S6141003	1	S6221003	1	S6221003	1	S6251003	1	
33	Accumulator Cover	S6141001	1	S6221001	1	S6221001	1	S6251001	1	
34	Hex Bolt	/	4	/	4	/	4	/	4	
35	Hex Bolt	/	12	/	16	/	16	/	16	
36	O-Ring	B2002014	1	B2002014	1	B2002014	1	B2002014	1	
37	P. V. C Plug	B7003203	1	B7003203	1	B7003203	1	B7003203	1	
38	O-Ring	B2002005	1	B2002005	1	B2002005	1	B2002005	1	
39	Accumulator Charging	B7003201	1	B7003201	1	B7003201	1	B7003201	1	
40	O-Ring	B2002014	1	B2002014	1	B2002014	1	B2002014	1	
41	Cap	B7003202	1	B7003202	1	B7003202	1	B7003202	1	

**MAIN BODY (NS140A,NS155,NS165,NS175)**

NO	PARTS NAME	NS140A		NS155		NS165		NS175		Remark
		P/N	Qty	P/N	Qty	P/N	Qty	P/N	Qty	
46	Back Head	S4141001	1	S4221001	1	S4231001	1	S4251001	1	
47	O-Ring	B2002018	1	B2002018	1	B2002018	1	B2002018	1	
48	Charging Valve	B7003021	1	B7003021	1	B7003021	1	B7003021	1	
49	Front Head	S2141001	1	S2221001	1	S2231001	1	S2251001	1	
50	Thrust Bush	S2141003	1	S2221003	1	S2231003	1	S2251003	1	
51	Front Bush	S2141002	1	S2221002	1	S2231002	1	S2251002	1	
52	Rod Pin	S2141004	2	S2221004	2	S2221004	2	S2251004	2	
53	Front Cover Pin	S2141005	2	S2221005	2	S2221005	2	S2251005	2	
54	Thrust Bush Pin	S2141006	1	S2221006	2	S2231006	1	S2251006	1	
55	Stop Pin	S2141007	2	S2221007	2	S2231007	2	S2251007	2	
56	Rubber For Front Cover Pin	B7007330	2	B7007326	2	B7007326	2	B7007336	2	
57	Spring Pin For Front Cover Pin	B7007230	2	B7007226	2	B7007226	2	B7007236	2	
58	Rubber For Front Bush Pin	B7007320	1	B7007317	1	B7007317	1	B7007326	2	
59	Spring Pin	/	/	B7007217	1	B7007217	1	B7007226	2	
60	Rubber For Spring Pin/Stop Pin	B7007320	1	B7007317	1	B7007317	1	B7007318	1	
61	Spring Pin	/	/	/	/	/	/	/	/	
62	Grease Nipple	B7005001	1	B7005001	1	B7005001	1	B7005001	1	
63	O-Ring	B2002018	1	B2002018	1	B2002018	1	B2002018	1	
64	Air Check Valve	B7004021	1	B7004021	1	B7004021	1	B7004021	1	
	<b>Through Bolt Ass'y</b>	S8151000	/	S8221000	/	S8231000	/	S8251000	/	
65	Nuts For Through Bolt	S8141002	4	S8221002	4	S8221002	4	S8251002	4	
66	Through Bolt	S8141001	4	S8221001	4	S8231001	4	S8251001	4	
67	Washer	S8141004	4	S8221004	4	S8221004	4	S8251004	4	
68	Hex Bolt	S8141003	4	S8221003	4	S8221003	4	S8251003	4	
69	Locked Pin	B7007112	2	B7007112	2	B7007112	2	B7007118	2	
70	Rod(Moil Point)	B1143000	1	B1223000	1	B1233000	1	B1253000	1	
70-2	Rod(Blunt)	B1142000		B1222000		B1232000		B1252000		
70-3	Rod(Wedge)	B1144000		B1224000		B1234000		B1254000		
70-4	Rod(Cone)	B1141000		B1221000		B1231000		B1251000		

Parts and accessories list (NS120,NS135A)

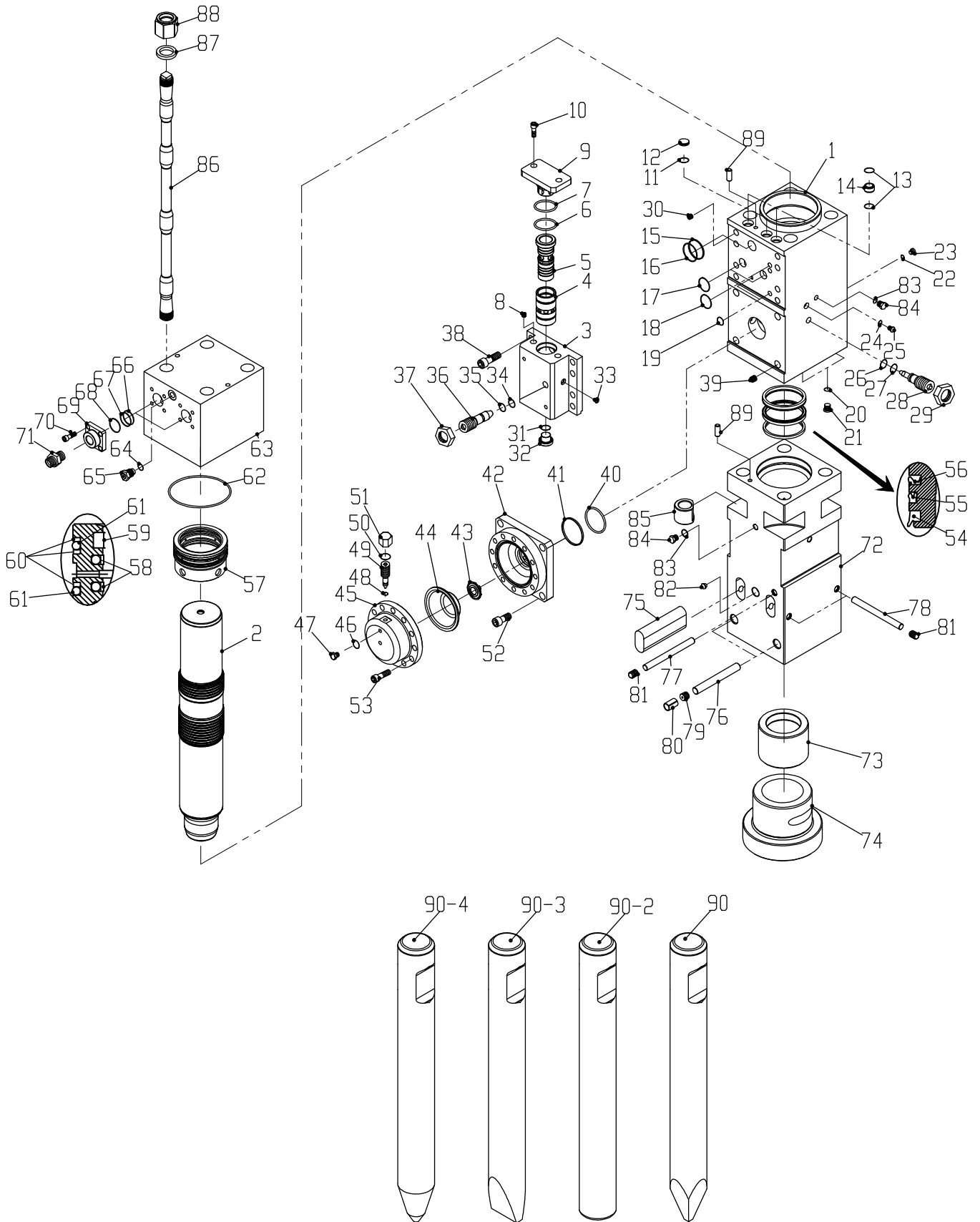

## MAIN BODY (NS120,135A)

NO	PARTS NAME	NS120		NS135A		Remark
		P/N	Qty	P/N	Qty	
1	Cylinder	S3501001	1	S3701001	1	
2	Piston	S3501002	1	S3701002	1	
	<b>Valve Assy's</b>	S5501000	/	S5701000	/	
3	Valve Cover	S5501001	1	S5701001	1	
4	Valve Sleeve	S5501002	1	S5701002	1	
5	Valve	S5501003	1	S5701003	1	
6	O-Ring	B2001055	1	B2001060	1	
7	O-Ring	/	/	B2003060	1	
8	Sleeve For Bolt	B7006020	2	B7006024	2	
9	O-Ring	S5501004	1	S5701004	1	
10	Hex Bolt	/	2	/		
11	O-Ring	B2001025	1	B2001030	1	
12	Plug	B7001330	1	B7001335	1	
13	O-Ring	B2002026	4	B2001030	4	
14	Oil Guide Tube	B7001232	2	B7001235	2	
15	O-Ring	B2001045	1	B2001045	1	
16	Rings For Shoulder	B2003045	1	B2003045	1	
17	O-Ring	B2001035	2	B2001040	2	
18	O-Ring	B2001040	1	B2001045	1	
19	O-Ring	B2001025	2	B2001030	2	
20	O-Ring	B2002011	2	B2002011	2	
21	Plug	B7001013	2	B7001013	2	
22	O-Ring	B2002011	1	B2002011	1	
23	Plug	B7001013	1	B7001013	1	
24	O-Ring	B2002011	1	B2002011	1	
25	Plug	B7001013	1	B7001013	1	
26	O-Ring	B2002011	1	B2002011	1	
27	Rings For Shoulder	B2003011	1	B2003011	1	
28	Valve Adjuster	B8502101	1	B8502101	1	
29	Nuts For Valve Adjuster	B8502102	2	B8502102	2	
30	Valve Adjuster	B7006020	8	B7006020	8	
31	O-Ring	B2002030	1	B2002030	1	
32	Plug	B7001034	1	B7001034	1	
33	Plug	B7001113	1	B7001113	1	
34	O-Ring	B2002011	1	/	/	
35	Rings For Shoulder	B2003011	1	/	/	
36	Valve Adjuster	B8501101	/	B8701101	1	
37	Nuts For Valve Adjuster	B8501102	/	B8701102	1	
38	Hex Bolt	/	8	/	8	
39	Sleeve For Bolt	B7006024	10	B7006024	10	

**MAIN BODY (NS120,NS135A)**

NO	PARTS NAME	NS120		NS135A		Remark
		P/N	Qty	P/N	Qty	
	<b>Accumulator Ass'y</b>	S6501000	/	S6701000	/	
40	Rings For Shoulder	B2003080	1	B2003080	1	
41	O-Ring	B2001080	1	B2001080	1	
42	Accumulator Body	S6501002	1	S6141002	1	
43	Holder	S6501004	1	S6141004	1	
44	Diaphragm	S6501003	1	S6141003	1	
45	Accumulator Cover	S6501001	1	S6141001	1	
46	O-Ring	B2002014	1	B2002014	1	
47	P. V. C Plug	B7003203	1	B7003203	1	
48	O-Ring	B2002005	1	B2002005	1	
49	Accumulator Charging	B7003201	1	B7003201	1	
50	O-Ring	B2002014	1	B2002014	1	
51	Cap	B7003202	1	B7003202	1	
52	Hex Bolt	/	4	/	4	
53	Hex Bolt	/	20	/	12	
	<b>Seal Kit</b>	B2501000	/	B2701000	/	
54	Dust Seal	B2501001	1	B2701001	1	
55	U-Packing	B2501002	1	B2701002	1	
56	Buffer Seal	B2501003	1	B2701003	1	
58	Step Seal	B2501007	2	B2701007	1	
59	Gas Seal	B2501008	1	B2701008	1	
60	Rings For Shoulder	B2004145	3	B2003165	3	
61	O-Ring	B2002145	2	B2001165	2	
62	O-Ring	B20011180	1	B2001200	1	
57	Seal Retainer	S3501004	1	S3701004	1	
63	Back Head	S4501001	1	S4701001	1	
64	O-Ring	B2002018	1	B2002018	1	
65	Charging Valve	B7003021	1	B7003021	1	
66	O-Ring	B2001040	2	B2001040	2	
67	Rings For Shoulder	B2003040	2	B2003040	2	
68	O-Ring	B2001055	2	B2001055	2	
69	Oil Tube Base	B7003045	2	B7003045	2	
70	Hex Bolt	/	8	/	8	
71	Adapter	B7002034	2	B7002034	2	
72	Front Head	S2501001	1	S2701001	1	
73	Thrust Bush	S2501003	/	S2701003	1	
74	Front Bush	S2501002	/	S2701002	1	
75	Rod Pin	S2501004	2	S2701004	2	
76	Front Cover Pin	S2501005	2	S2701005	2	
77	Spring Pin	S2501006	1	S2701007	1	
78	Stop Pin	S2501006	2	S2701006	2	
79	Rubber For Front Cover Pin	B7007326	1	B7007330	2	
80	Spring Pin For Front Cover Pin	B7007226	1	B7007230	2	
81	Rubber For Spring Pin/Stop Pin	B7007317	1	B7007320	1	
82	Grease Nipple	B7005001	1	B7005001	1	
83	O-Ring	B2002018	1	B2002018	1	
84	Air Check Valve	B7004021	1	B7004021	1	
	<b>Through Bolt Ass'y</b>	S8501000	/	S8701000	/	
85	Nuts For Through Bolt	S8501102	4	S8701102	4	
86	Through Bolt	S8501001	4	S8701001	4	
87	Washer	S8501004	4	S8701004	4	
88	Hex Nut	S8501003	4	S8701003	4	
89	Locked Pin	/	/	/	/	
90	Rod (Moil Point)	B1503000	1	B1703000	1	
90-2	Rod (Blunt)	B1502000		B1702000		
90-3	Rod (Wedge)	B1504000		B1704000		
90-4	Rod (Cone)	B1501000		B1701000		

# Parts and accessories list (NS185)

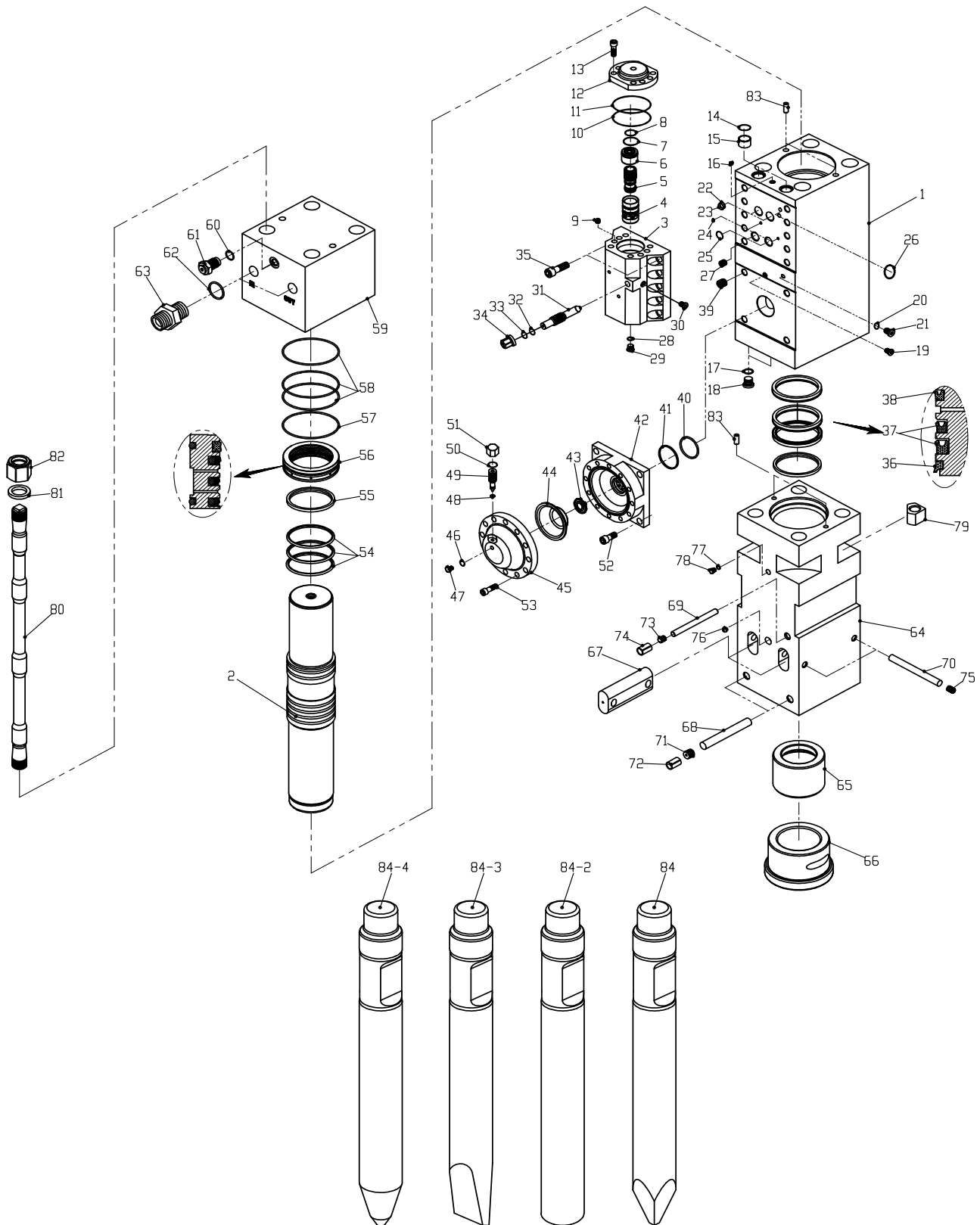

## MAIN BODY (NS185)

NO	PARTS NAME	NS185		Remark
		P/N	Qty	
1	Cylinder	S3581001	1	
2	Piston	S3581002	1	
	<b>Valve Ass'y</b>	S5581000	/	
3	Valve Cover	S5591001	1	
4	Valve Sleeve	S5591002	1	
5	Valve	S5591003	1	
6	Valve Plug	S5591004	1	
7	O-Ring	B2001100	1	
8	O-Ring	B2001060	1	
9	Sleeve For Bolt	B7006020	8	
10	O-Ring	B2002110	1	
11	Rings For Shoulder	B2004110	1	
12	Valve Cover	S5591005	1	
13	Hex Bolt	/	8	
14	O-Ring	B2002046	2	
15	Oil Guide Tube	B7001242	2	
16	Plug	B7001113	1	
17	O-Ring	B2002035	2	
18	Plug	B7001039	2	
19	Plug	B7001113	1	
20	O-Ring	B2002018	1	
21	Plug	B7001021	1	
22	O-Ring	B2001050	2	
23	Rings For Shoulder	B2003050	2	
22	O-Ring	B2001090	1	
23	Rings For Shoulder	B2003090	1	
24	O-Ring	B2001030	3	
25	O-Ring	B2001060	2	
26	O-Ring	B2001060	2	
27	Sleeve For Bolt	B7006024	10	
28	O-Ring	B2002018	1	
29	Plug	B7001021	1	
30	Plug	B7001118	1	
31	Valve Adjuster	B8591101	1	
32	O-Ring	B2002029	1	
33	O-Ring	B2002020	1	
34	Nuts For Valve Adjuster	B8591102	1	
35	Hex Bolt	/	10	
	<b>Seal Kit</b>	B2581000	/	
36	Dust Seal	B2581001	1	
37	U-Packing	B2581002	2	
38	Buffer Seal	B2581003	1	
54	Step Seal	B2581007	3	
55	Gas Seal	B2581008	1	
57	Rings For Shoulder	B2003230	1	
58	O-Ring	B2001230	3	
56	Seal Retainer	S3581004	1	
39	Sleeve For Bolt	B7006030	4	

## MAIN BODY (NS185)

NO	PARTS NAME	NS185		Remark
		P/N	Qty	
	<b>Accumulator Ass'y</b>	S6581000	/	
40	Rings For Shoulder	B2004100	1	
41	O-Ring	B2002100	1	
42	Accumulator Body	S6581002	1	
43	Holder	S6581004	1	
44	Diaphragm	S6581003	1	
45	Accumulator Cover	S6581001	1	
46	O-Ring	B2002014	1	
47	P. V. C Plug	B7003203	1	
48	O-Ring	B2002005	1	
49	Accumulator Charging	B7003201	1	
50	O-Ring	B2002014	1	
51	Cap	B7003202	1	
52	Hex Bolt	/	4	
53	Hex Bolt	/	20	
59	Back Head	S4581001	1	
60	O-Ring	B2002018	1	
61	Charging Valve	B7003021	1	
62	O-Ring	B2002038	2	
63	Adapter	B7002041	2	
64	Front Head	S2581001	1	
65	Thrust Bush	S2581003	1	
66	Front Bush	S2581002	1	
67	Rod Pin	S2581004	2	
68	Front Cover Pin	S2581005	2	
69	Spring Pin	S2581006	1	
70	Stop Pin	S2581007	2	
71	Rubber For Front Cover Pin	B7007336	2	
72	Spring Pin For Front Cover Pin	B7007236	2	
73	Rubber For Spring Pin/Stop Pin	B7007326	2	
74	Spring Pin	B7007226	2	
75	Rubber For Spring Pin/Stop Pin	B7007326	2	
76	Grease Nipple	B7005001	1	
77	O-Ring	B2002018	1	
78	Air Check Valve	B7004021	1	
	<b>Through Bolt Ass'y</b>	S8581000	/	
79	Nuts For Through Bolt	S8581002	4	
80	Through Bolt	S8581001	4	
81	Washer	S8581004	4	
82	Hex Nut	S8581003	4	
83	Locked Pin	B7007117	4	
84	Rod (Moil Point)	B1583000	1	
84-2	Rod (Blunt)	B1582000		
84-3	Rod (Wedge)	B1584000		
84-4	Rod (Cone)	B1581000		

Parts and accessories list (NS190)

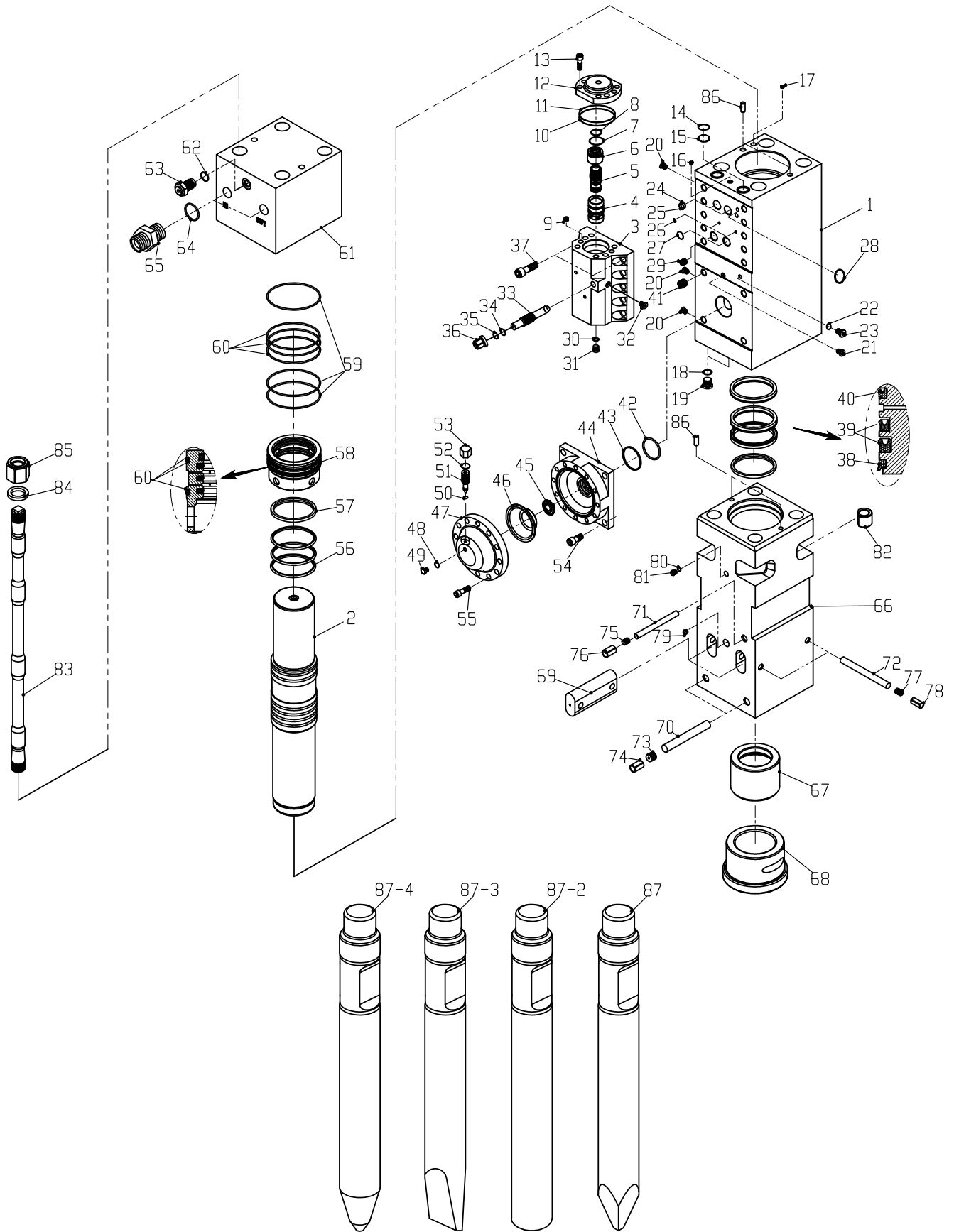

## MAIN BODY (NS190)

NO	PARTS NAME	NS190		Remark
		P/N	Qty	
1	Cylinder	S3591001	1	
2	Piston	S3591002	1	
	<b>Valve Ass'y</b>	S5591000	/	
3	Valve Cover	S5591001	1	
4	Valve Sleeve	S5591002	1	
5	Valve	S5591003	1	
6	Valve Plug	S5591004	1	
7	O-Ring	B2001100	1	
8	O-Ring	B2001060	1	
9	Sleeve For Bolt	B7006020	8	
10	O-Ring	B2002110	1	
11	Rings For Shoulder	B2004110	1	
12	Valve Cover	S5591005	1	
13	Hex Bolt	/	8	
14	O-Ring	B2001050	2	
15	Rings For Shoulder	B2003050	2	
16	Plug	B7001113	1	
17	Plug	B7001118	1	
18	O-Ring	B2002035	2	
19	Plug	B7001039	2	
20	Plug	B7001113	3	
21	Plug	B7001113	4	
22	O-Ring	B2002018	1	
23	Plug	B7001021	1	
24	O-Ring	B2001050	2	
25	Rings For Shoulder	B2003050	2	
24	O-Ring	B2001090	1	
25	Rings For Shoulder	B2003090	1	
26	O-Ring	B2001030	3	
27	O-Ring	B2001060	2	
28	O-Ring	B2001060	2	
29	Sleeve For Bolt	B7006024	10	
30	O-Ring	B2002018	1	
31	Plug	B7001021	1	
32	Plug	B7001118	1	
33	Valve Adjuster	B8591101	1	
34	O-Ring	B2002029	1	
35	O-Ring	B2002022	1	
36	Nuts For Valve Adjuster	B8591102	1	
37	Hex Bolt	/	10	
	<b>Seal Kit</b>	B2591000	/	
38	Dust Seal	B2591001	1	
39	U-Packing	B2591002	2	
40	Buffer Seal	B2591003	1	
56	Step Seal	B2591007	3	
57	Gas Seal	B2591008	1	
59	Rings For Shoulder	B2003230	3	
60	O-Ring	B2001230	3	
58	Seal Retainer	S3591004	1	
41	Sleeve For Bolt	B7006033	4	

**MAIN BODY (NS190)**

NO	PARTS NAME	NS190		Remark
		P/N	Qty	
	<b>Accumulator Ass'y</b>	S6591000	/	
42	Rings For Shoulder	B2004110	1	
43	O-Ring	B2002110	1	
44	Accumulator Body	S6591002	1	
45	Holder	S6591004	1	
46	Diaphragm	S6591003	1	
47	Accumulator Cover	S6591001	1	
48	O-Ring	B2002014	1	
49	P. V. C Plug	B7003203	1	
50	O-Ring	B2002005	1	
51	Accumulator Charging	B7003201	1	
52	O-Ring	B2002014	1	
53	Cap	B7003202	1	
54	Hex Bolt	/	4	
55	Hex Bolt	/	20	
61	Back Head	S4591001	1	
62	O-Ring	B2002018	1	
63	Charging Valve	B7003021	1	
64	O-Ring	B2002044	2	
65	Adapter	B7002048	2	
66	Front Head	S2591001	1	
67	Thrust Bush	S2591003	1	
68	Front Bush	S2591002	1	
69	Rod Pin	S2591004	2	
70	Front Cover Pin	S2591005	2	
71	Spring Pin	S2591005	1	
72	Stop Pin	S2591007	2	
73	Rubber For Front Cover Pin	B7007326	2	
74	Spring Pin For Front Cover Pin	B7007226	2	
75	Rubber For Spring Pin/Stop Pin	B7007326	1	
76	Spring Pin	B7007226	1	
77	Rubber For Spring Pin/Stop Pin	B7007326	1	
78	Spring Pin	B7007226	1	
79	Grease Nipple	B7005001	1	
80	O-Ring	B2002018	1	
81	Air Check Valve	B7004021	1	
	<b>Through Bolt Ass'y</b>	S8591000	/	
82	Nuts For Through Bolt	S8591102	4	
83	Through Bolt	S8591001	4	
84	Washer	S8591004	4	
85	Hex Nut	S8591003	4	
86	Locked Pin	B7007117	4	
87	Rod (Moil Point)	B1593000	1	
87-2	Rod (Blunt)	B1592000		
87-3	Rod (Wedge)	B1594000		
87-4	Rod (Cone)	B1591000		

Parts and accessories list (NS195)

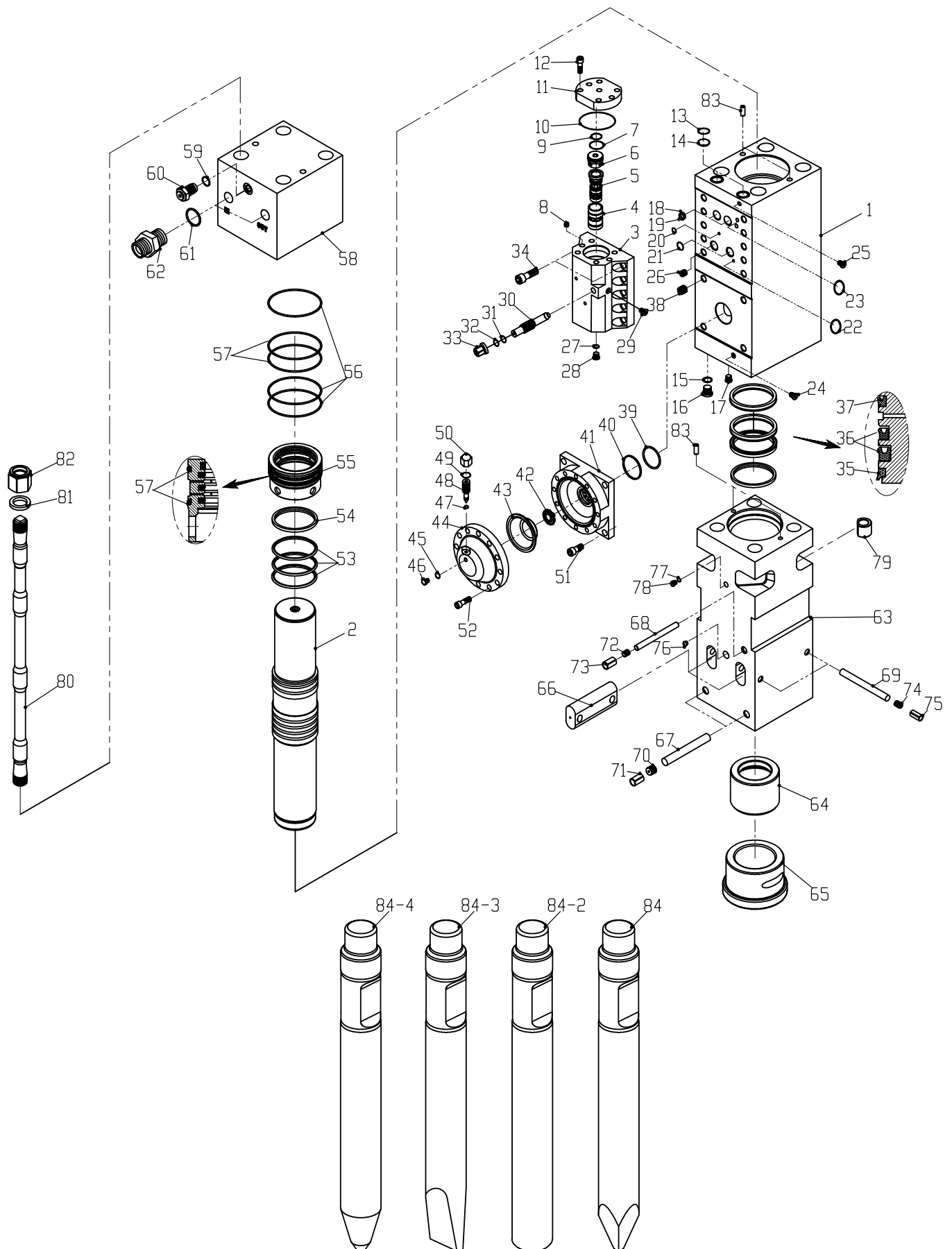

## MAIN BODY (NS195)

NO	PARTS NAME	NS195		Remark
		P/N	Qty	
1	Cylinder	S3601001	1	
2	Piston	S3601002	1	
	<b>Valve Ass'y</b>	S5601000	/	
3	Valve Cover	S5601001	1	
4	Valve Sleeve	S5601002	1	
5	Valve	S5601003	1	
6	Valve Plug	S5601004	1	
7	O-Ring	B2001100	1	
8	Sleeve For Bolt	B7006024	6	
9	O-Ring	B2001070	1	
10	O-Ring	B2001115	1	
11	Valve Cover	S5601005	1	
12	Hex Bolt	/	6	
13	O-Ring	B2001055	2	
14	Rings For Shoulder	B2003055	2	
15	O-Ring	B2002035	1	
16	Plug	B7001039	1	
17	Plug	B7001121	1	
18	O-Ring	B2001055	2	
19	Rings For Shoulder	B2003055	2	
20	O-Ring	B2001040	1	
21	O-Ring	B2001055	2	
22	O-Ring	B2001055	1	
23	O-Ring	B2001065	1	
24	Plug	B7001113	1	
25	Plug	B7001113	1	
26	Sleeve For Bolt	B7006030	10	
27	O-Ring	B2002018	1	
28	Plug	B7001021	1	
29	Plug	B7001118	1	
30	Valve Adjuster	B8591101	1	
31	O-Ring	B2002029	1	
32	O-Ring	B2002022	1	
33	Nuts For Valve Adjuster	B8591102	1	
34	Hex Bolt	/	10	
	<b>Seal Kit</b>	B2601000	/	
35	Dust Seal	B2601001	1	
36	U-Packing	B2601002	2	
37	Buffer Seal	B2601003	1	
53	Step Seal	B2601007	3	
54	Gas Seal	B2601008	1	
56	O-Ring	B2001250	3	
57	Rings For Shoulder	B2003250	2	
55	Seal Retainer	S3601004	1	
38	Sleeve For Bolt	B7006033	4	

## MAIN BODY (NS195)

NO	PARTS NAME	NS195		Remark
		P/N	Qty	
	<b>Accumulator Ass'y</b>			
39	Rings For Shoulder	B2004110	1	
40	O-Ring	B2002110	1	
41	Accumulator Body	S6591002	1	
42	Holder	S6591004	1	
43	Diaphragm	S6591003	1	
44	Accumulator Cover	S6591001	1	
45	O-Ring	B2002014	1	
46	P.V.C Plug	B7003203	1	
47	O-Ring	B2002005	1	
48	Accumulator Charging	B7003201	1	
49	O-Ring	B2002014	1	
50	Cap	B7003202	1	
51	Hex Bolt	/	4	
52	Hex Bolt	/	20	
58	Back Head	S4601001	1	
59	O-Ring	B2002018	1	
60	Charging Valve	B7003021	1	
61	O-Ring	B2002044	2	
62	Adapter	B7002048	2	
63	Front Head	S2601001	1	
64	Thrust Bush	S2601003	1	
65	Front Bush	S2601002	1	
66	Rod Pin	S2601004	2	
67	Front Cover Pin	S2601005	2	
68	Spring Pin	S2601006	1	
69	Stop Pin	S2601006	2	
70	Rubber For Front Cover Pin	B7007336	2	
71	Spring Pin For Front Cover Pin	B7007236	2	
72	Rubber For Spring Pin/Stop Pin	B7007326	1	
73	Spring Pin	B7007226	1	
74	Rubber For Spring Pin/Stop Pin	B7007326	1	
75	Spring Pin	B7007226	1	
76	Grease Nipple	B7005001	1	
77	O-Ring	B2002018	1	
78	Air Check Valve	B7004021	1	
	<b>Through Bolt Ass'y</b>	S8601000	/	
79	Nuts For Through Bolt	S8601102	4	
80	Through Bolt	S8601001	4	
81	Washer	S8601004	4	
82	Hex Nut	S8601003	4	
83	Locked Pin	B7007119	4	
84	Rod (Moil Point)	B1603000	1	
84-2	Rod (Blunt)	B1602000		
84-3	Rod (Wedge)	B1604000		
84-4	Rod (Cone)	B1601000		

Case Parts accessories list

SIDE TYPE(NS40,NS45,NS53)

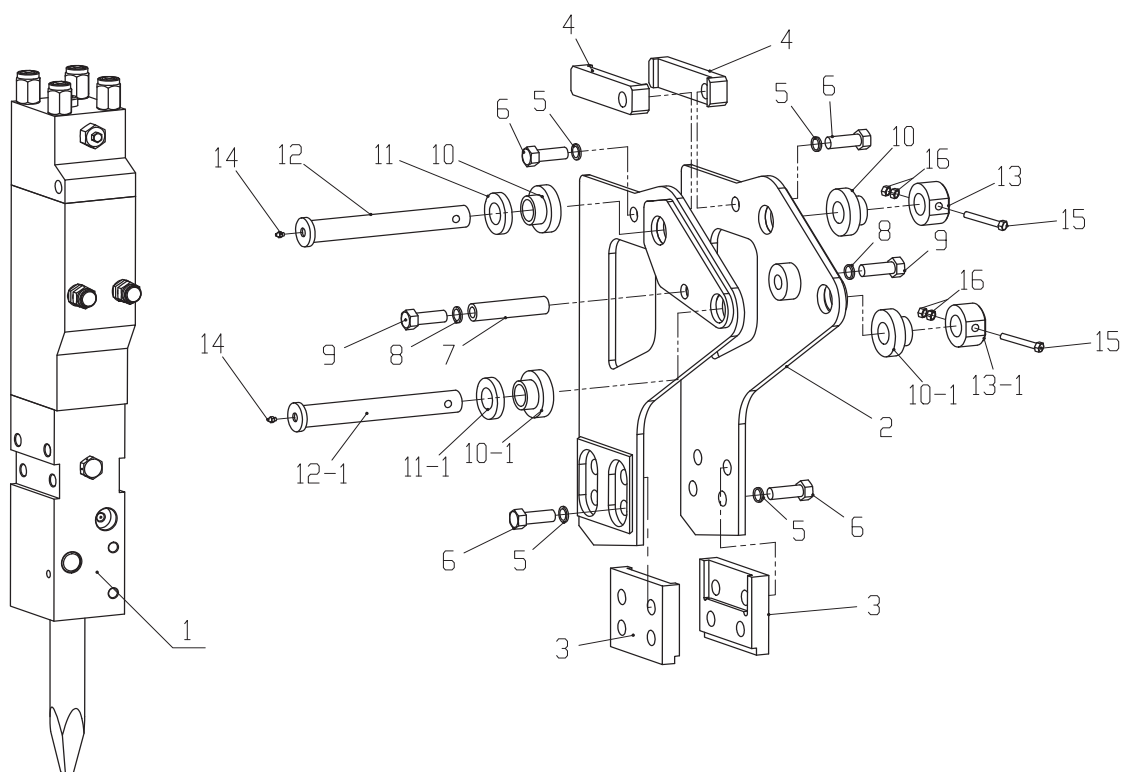

NO	PARTS NAME	NS40		NS45		NS53		REMARKS
		P/N	Qty	P/N	Qty	P/N	Qty	
1	Body Ass'y	S1031000	1	S1041000	1	S1061000	1	
2	Frame	S7031101	2	S7041101	1	S7061101	1	
3	Side Plate	S7031102	2	S7041102	2	S7061102	2	
4	Guide Plate	S7031103	2	S7041103	2	S7061103	2	
5	Washer	/	10	/	10	/	10	
6	Side Nut	/	10	/	10	/	10	
7	support shaft	S7031104	1	/	-	/	/	
8	Washer	/	2	/	/	/	/	
9	Side Nut	/	2	/	/	/	/	
10	upper shaft sleeve	S7031105	2	S7041105	2	S7061105	2	
11	Washer	S7031106	1	S7041106	1	S7061106	1	
12	upper bucket spindle	S7031107	1	S7041107	1	S7061107	1	
13	upper ring	S7031108	2	S7041108	1	S7061108	2	
10-1	lower shaft sleeve	S7031105-1	2	S7041105-1	2	S7061105-1	2	
11-1	Washer	S7031106-1	1	S7041106-1	1	S7061106-1	1	
12-1	lower bucket spindle	S7031107-1	1	S7041107-1	1	S7061107-1	1	
13-1	lower ring	S7031108-1	1	S7041108-1	1	S7061108-1	1	
14	Grease Nipple	B7005003	2	←	2	←	2	
15	Side Nut	/	2	/	2	/	2	
16	Side Bolt	/	4	/	4	/	4	

### Case Parts accessories list

## SIDE TYPE(NS68,NS75,NS85,NS100)

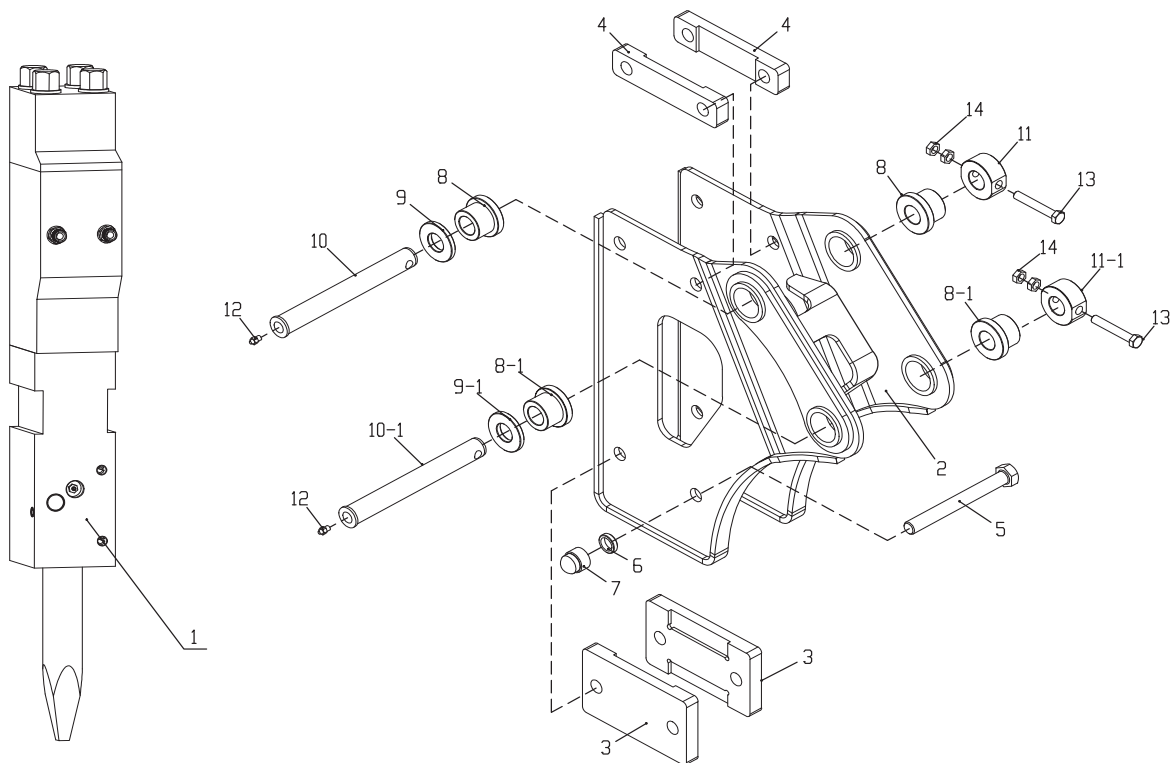

NO	PARTS NAME	NS68		NS75		NS85		NS100		REMARKS
		P/N	Qty	P/N	Qty	P/N	Qty	P/N	Qty	
1	Body Ass'y	S1071000	1	S1081000	1	S1091000	1	S1111000	1	
2	Frame	S7071101	1	S7081101	1	S7091101	1	S7111101	1	
3	Side Plate	S7071102	2	S7081102	2	S7091102	2	S7111102	2	
4	Guide Plate	S7071103	2	S7081103	2	S7091103	2	S7111103	2	
5	Flush Bolt	S7071901	4	S7081901	6	S7091901	6	S7111901	6	
6	Washer	S7071902	4	S7081902	6	S7081902	6	S7111902	6	
7	Side Bolt	S7071903	4	S7081903	6	S7081903	6	S7111903	6	
8	upper shaft sleeve	S7071105	2	S7081105	2	S7091105	2	S7111105	2	
9	Washer	S7071106	1	S7081106	1	S7091106	1	S7111106	1	
10	upper bucket spindle	S7071107	1	S7081107	1	S7091107	1	S7111107	1	
11	upper ring	S7071108	1	S7081108	1	S7091108	1	S7111108	1	
8-1	lower shaft sleeve	S7071105-1	2	S7081105-1	2	S7091105-1	2	S7111105-1	2	
9-1	Washer	S7071106-1	1	S7081106-1	1	S7091106-1	1	S7111106-1	1	
10-1	lower bucket spindle	S7071107-1	1	S7081107-1	1	S7091107-1	1	S7111107-1	1	
11-1	lower ring	S7071108-1	1	S7081108-1	1	S7091108-1	1	S7111108-1	1	
12	Grease Nipple	B7005003	2	←	2	←	2	←	2	
13	Side Nut	/	2	/	2	/	2	/	2	
14	Side Bolt	/	4	/	4	/	4	/	4	

### Case Parts accessories list

### SIDE TYPE(NS140A,NS155,NS165)

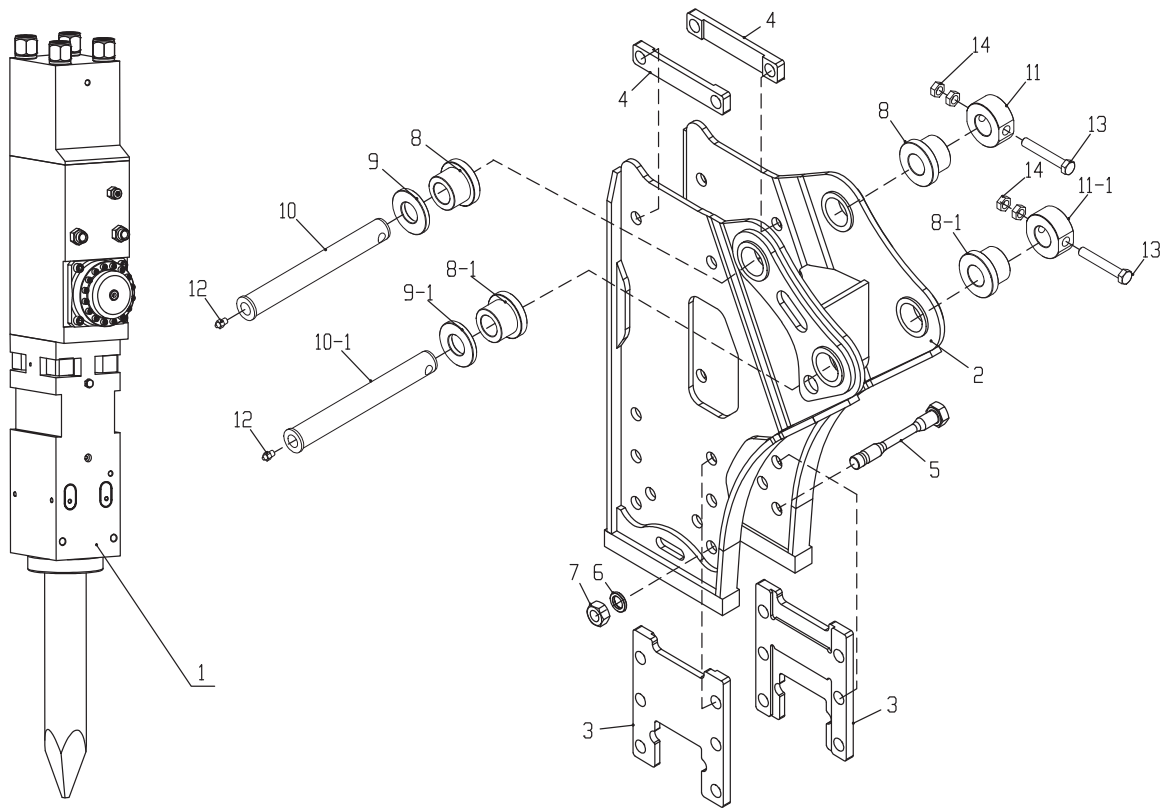

NO	PARTS NAME	NS140A		NS155		NS165		REMARKS
		P/N	Qty	P/N	Qty	P/N	Qty	
1	Body Ass'y	S1151000	1	S1221000	1	S1231000	1	
2	Frame	S7141101	1	S7221101	1	S7231101	1	
3	Side Plate	S7141102	2	S7221102	2	S7231102	2	
4	Guide Plate	S7141103	2	S7221103	2	S7231103	2	
5	Flush Bolt	S7141901	8	S7221901	8	S7231901	10	
6	Washer	S7131902	8	S7221902	8	S7221902	10	
7	Side Bolt	S7131903	8	S7221903	16	S7221903	20	
8	upper shaft sleeve	S7141105	2	S7221105	2	S7231105	2	
9	Washer	S7141106	1	S7221106	1	S7231106	1	
10	upper bucket spindle	S7141107	1	S7221107	1	S7231107	1	
11	upper ring	S7141108	1	S7221108	1	S7231108	1	
8-1	lower shaft sleeve	S7141105-1	2	S7221105-1	2	S7231105-1	2	
9-1	Washer	S7141106-1	1	S7221106-1	1	S7231106-1	1	
10-1	lower bucket spindle	S7141107-1	1	S7221107-1	1	S7231107-1	1	
11-1	lower ring	S7141108-1	1	S7221108-1	1	S7231108-1	1	
12	Grease Nipple	B7005003	2	←	2	←	2	
13	Side Nut	/	2	/	2	/	2	
14	Side Bolt	/	4	/	4	/	4	

## Case Parts accessories list

## SIDE TYPE(NS175,NS185,NS190,NS195)

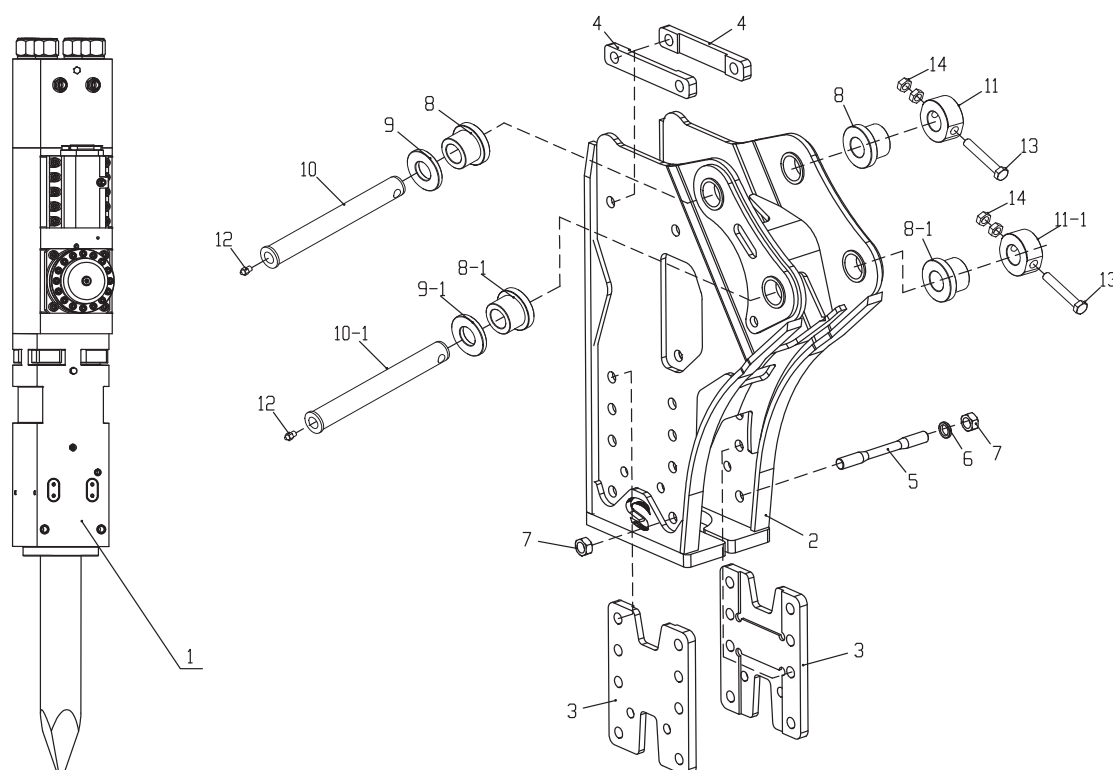

NO	PARTS NAME	NS175		NS185		NS190		NS195		REMARKS
		P/N	Qty	P/N	Qty	P/N	Qty	P/N	Qty	
1	Body Ass'y	S1251000	1	S1581000	1	S1591000	1	S1601000	1	
2	Frame	S7251101	1	S7581101	1	S7591101	1	S7601101	1	
3	Side Plate	S7251102	2	S7581102	2	S7591102	2	S7601102	2	
4	Guide Plate	S7251103	2	S7581103	2	S7591103	2	S7601103	2	
5	Flush Bolt	S7251901	10	S7581901	10	S7591901	10	S7601901	10	
6	Washer	S7221902	10	S7221902	10	S7221902	10	S7601902	10	
7	Side Bolt	S7221903	20	S7221903	20	S7221903	20	S7601903	20	
8	upper shaft sleeve	S7251105	2	S7581105	2	S7591105	2	S7601105	2	
9	Washer	S7251106	1	S7581106	1	S7591106	1	S7601106	1	
10	upper bucket spindle	S7251107	1	S7581107	1	S7591107	1	S7601107	1	
11	upper ring	S7251108	1	S7581108	1	S7591108	1	S7601108	1	
8-1	lower shaft sleeve	S7251105-1	2	S7581105-1	2	S7591105-1	2	S7601105-1	2	
9-1	Washer	S7251106-1	1	S7581106-1	1	S7591106-1	1	S7601106-1	1	
10-1	lower bucket spindle	S7251107-1	1	S7581107-1	1	S7591107-1	1	S7601107-1	1	
11-1	lower ring	S7251108-1	1	S7581108-1	1	S7591108-1	1	S7601108-1	1	
12	Grease Nipple	B7005003	2	←	2	←	2	←	2	
13	Side Nut	/	2	/	2	/	2	/	2	
14	Side Bolt	/	4	/	4	/	4	/	4	

Case Parts accessories list

TOP TYPE(NS40,NS45,NS53)

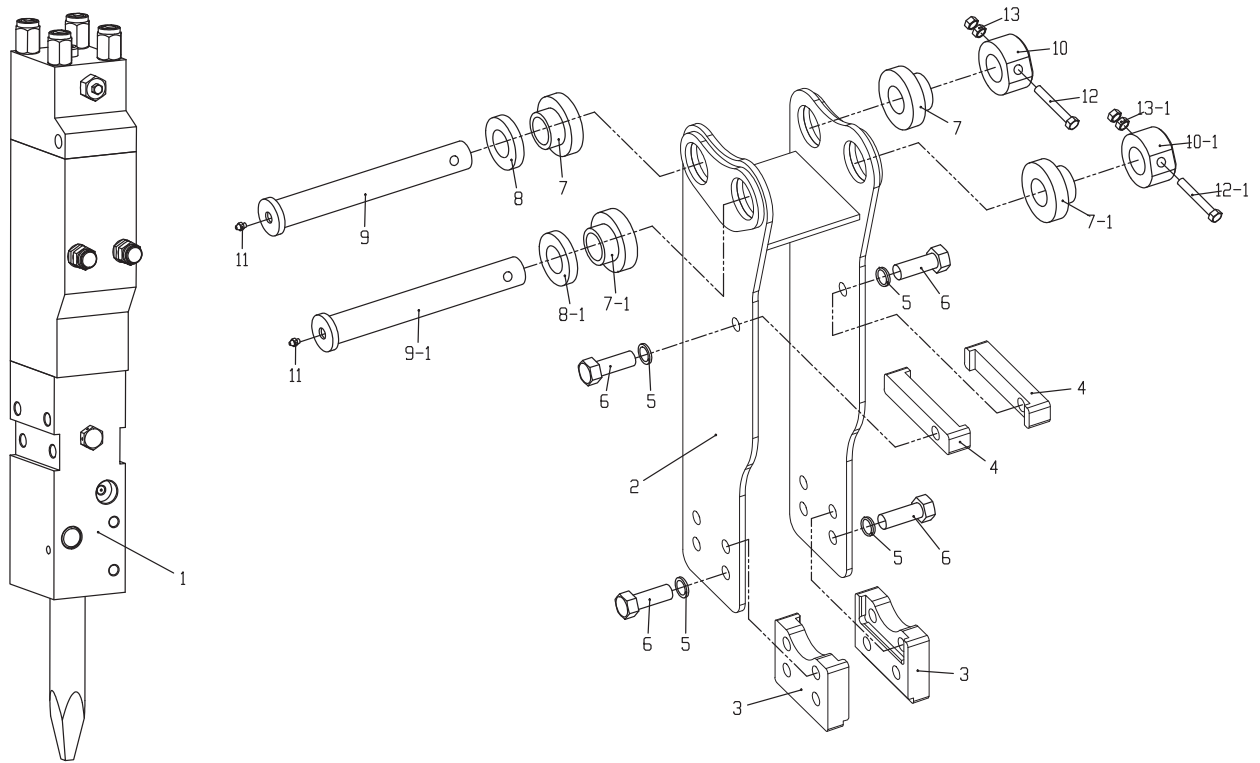

NO	PARTS NAME	NS40		NS45		NS53		REMARKS
		P/N	Qty	P/N	Qty	P/N	Qty	
	Frame Ass'y	S7032100	/	S7042100	/	S7062100	/	
1	Body Ass'y	S1031000	1	S1041000	1	S1061000	1	
2	Frame	S7032101	1	S7042101	1	S7062101	1	
3	Side Plate	S7031102	2	S7041102	2	S7061102	2	
4	Guide Plate	S7031103	2	S7041103	2	S7061103	2	
5	Washer	/	10	/	10	/	10	
6	Side Nut	/	10	/	10	/	10	
7	Shaft Sleeve	S7032105	4	S7042105	4	S7062105	4	
8	Washer	S7032106	2	S7042106	2	S7062106	2	
9	Bucket Spindle	S7032107	2	S7042107	2	S7062107	2	
10	Ring	S7032108	2	S7042108	2	S7062108	2	
11	Grease Nipple	B7005003	2	←	2	←	2	
12	Side Nut	/	2	/	2	/	2	
13	Side Bolt	/	4	/	4	/	4	

Case Parts accessories list

TOP TYPE(NS68,NS75,NS85,NS100)

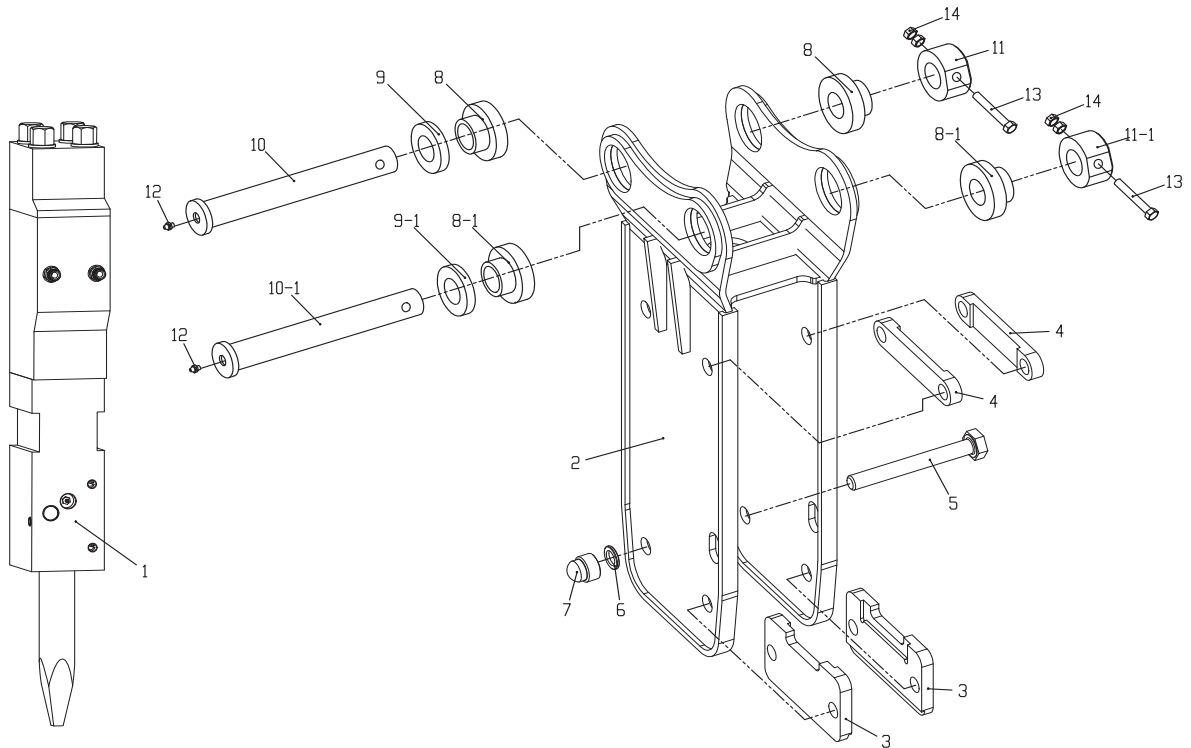

NO	PARTS NAME	NS68		NS75		NS85		NS100		REMARKS
		P/N	Qty	P/N	Qty	P/N	Qty	P/N	Qty	
	Frame Ass'y	S7072100	/	S7082100	/	S7092100	/	S7112100	/	
1	Body Ass'y	S1071000	1	S1081000	1	S1091000	1	S1111000	1	
2	Frame	S7072101	1	S7082101	1	S7092101	1	S7112101	1	
3	Side Plate	S7071102	2	S7081102	2	S7091102	2	S7111102	2	
4	Guide Plate	S7071103	2	S7081103	2	S7091103	2	S7111103	2	
5	Flush Bolt	S7071901	4	S7081901	6	S7091901	6	S7111901	6	
6	Washer	S7071902	4	S7081902	6	S7091902	6	S7111902	6	
7	Side Bolt	S7071903	4	S7081903	6	S7091903	6	S7111903	6	
8	Shaft Sleeve	S7072105	4	S7082105	4	S7092105	4	S7112105	4	
9	Washer	S7072106	2	S7082106	2	S7092106	2	S7112106	2	
10	Bucket Spindle	S7072107	2	S7082107	2	S7092107	2	S7112107	2	
11	Ring	S7072108	2	S7082108	2	S7092108	2	S7112108	2	
12	Grease Nipple	B7005003	2	←	2	←	2	←	2	
13	Side Nut	/	2	/	2	/	2	/	2	
14	Side Bolt	/	4	/	4	/	4	/	4	

Case Parts accessories list

TOP TYPE(NS140A,NS155,NS165)

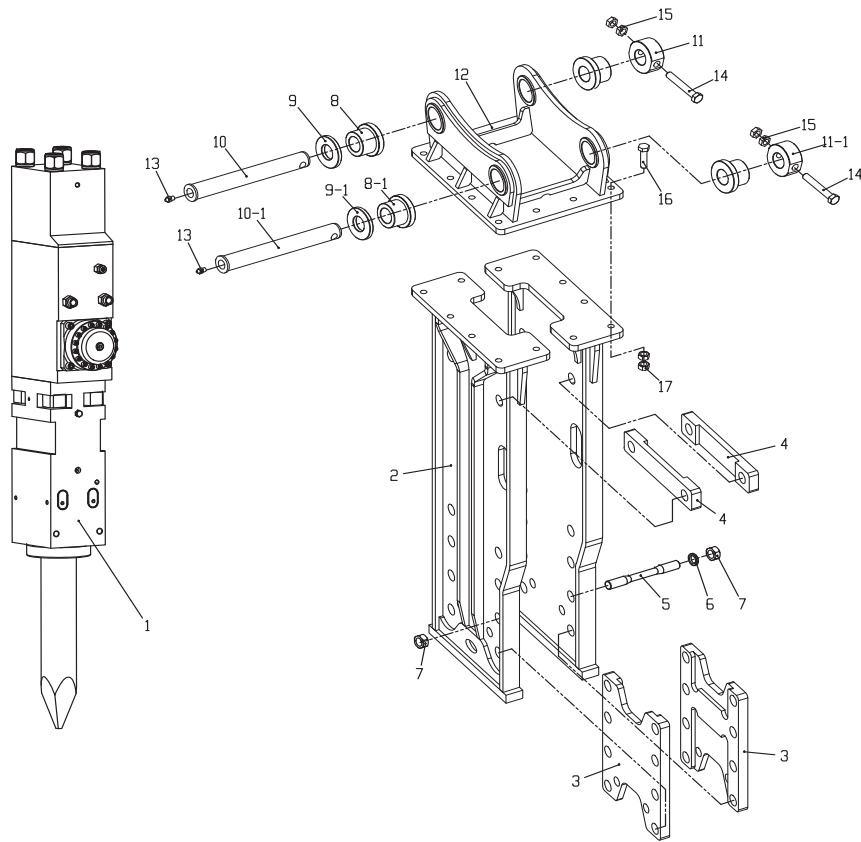

NO	PARTS NAME	NS140A		NS155		NS165		REMARKS
		P/N	Qty	P/N	Qty	P/N	Qty	
	Frame Ass'y	S7532100	/	S7542100	/	S7552100	/	
1	Body Ass'y	S1531000	1	S1541000	1	S1551000	1	
2	Frame	S7532101	1	S7542101	1	S7552101	1	
3	Side Plate	S7531102	2	S7541102	2	S7551102	2	
4	Guide Plate	S7531103	2	S7541103	2	S7551103	2	
5	Flush Bolt	S7141901	8	S7221901	10	S7551901	10	
6	Washer	S7131902	8	S7221902	10	S7221902	10	
7	Side Nut	S7131903	8	S7221903	20	S7221903	20	
8	Shaft Sleeve	S7532105	4	S7542105	4	S7552105	4	
9	Washer	S7532106	2	S7542106	2	S7552106	2	
10	Bucket Spindle	S7532107	2	S7542107	2	S7552107	2	
11	Ring	S7532108	2	S7542108	2	S7552108	2	
12	Connector	S7532104	1	S7542104	1	S7552104	1	
13	Grease Nipple	B7005003	2	←	2	←	2	
14	Side Nut	/	2	/	2	/	2	
15	Side Bolt	/	4	/	4	/	4	
16	M30 Nut	/	/	/	/	/	12	
17	M30 Bolt	/	/	/	/	/	24	

## Case Parts accessories list

## TOP TYPE(NS175,NS185,NS190)

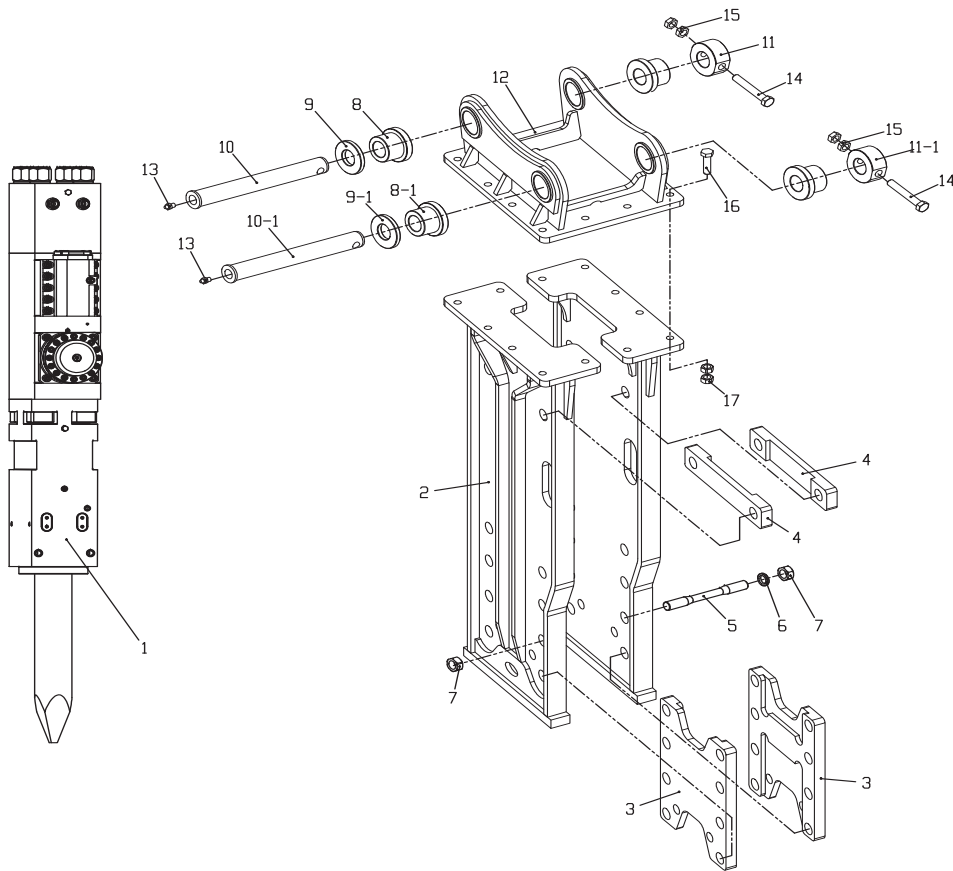

NO	PARTS NAME	NS175		NS185		NS190		REMARKS
		P/N	Qty	P/N	Qty	P/N	Qty	
	Frame Ass'y	S7572100	/	S7582100	/	S7592100	/	
1	Body Ass'y	S1571000	1	S1581000	1	S1591000	1	
2	Frame	S7572101	1	S7582101	1	S7592101	1	
3	Side Plate	S7571102	2	S7581102	2	S7591102	2	
4	Guide Plate	S7571103	2	S7581103	2	S7591103	2	
5	Flush Bolt	S7251901	10	S7581901	10	S7591901	10	
6	Washer	S7221902	10	S7221902	10	S7221902	10	
7	Side Nut	S7221903	20	S7221903	20	S7221903	20	
8	Shaft Sleeve	S7572105	2	S7582105	2	S7592105	2	
9	Washer	S7572106	1	S7582106	1	S7592106	1	
10	Bucket Spindle	S7572107	1	S7582107	1	S7592107	1	
11	Ring	S7572108	1	S7582108	1	S7592108	1	
12	Connector	S7572104	1	S7582104	1	S7592104	1	
13	Grease Nipple	B7005003	2	←	2	←	2	
14	Side Nut	/	2	/	2	/	2	
15	Side Bolt	/	4	/	4	/	4	
16	M36 Nut	/	12	/	/	/	/	
17	M36 Bolt	/	24	/	/	/	/	

Case Parts accessories list

BOX TYPE(NS40,NS45,NS53)

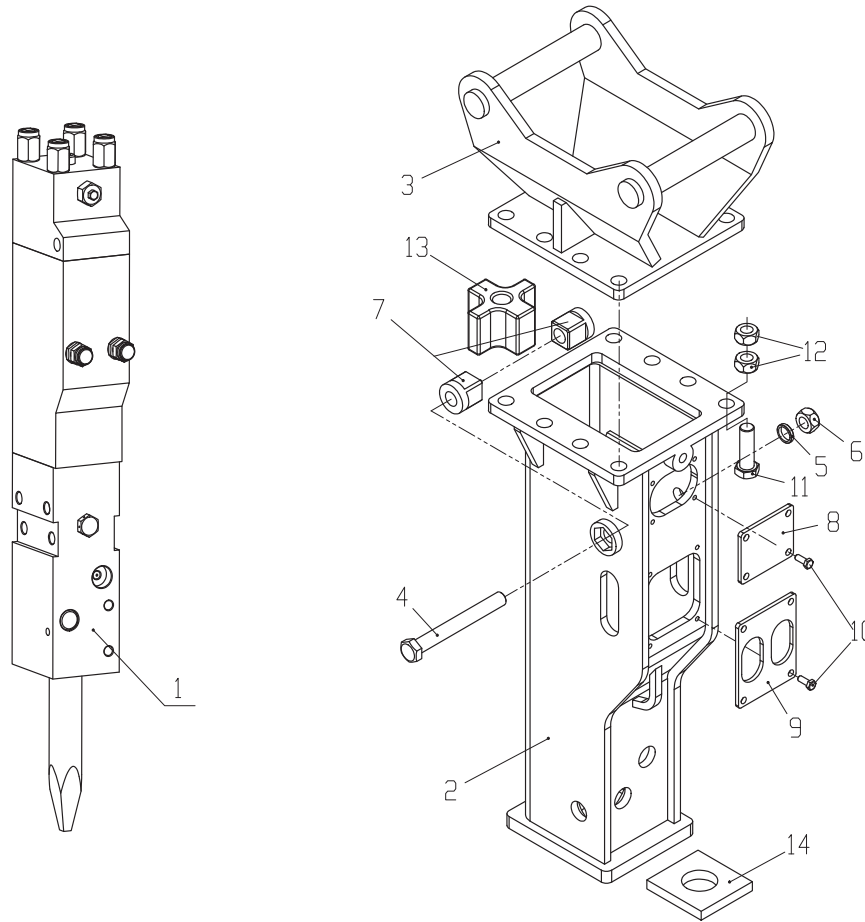

NO	PARTS NAME	NS40		NS45		NS53		REMARKS
		P/N	Qty	P/N	Qty	P/N	Qty	
	Frame Ass'y	S7033200	/	S7043200	/	S7063200	/	
1	Body Ass'y	S1031000	1	S1041000	1	S1061000	1	
2	Frame	S7033201	1	S7043201	1	S7063201	1	
3	Connecting Head	S7033202	1	S7033202	1	S7063202	1	
4	Flush Bolt	H41120170	1	H41120190	1	H41120190	1	
5	Washer	H49020300	1	H49020300	1	H49020300	1	
6	Side Bolt	H48120110	1	H48120110	1	H48120110	1	
7	Fixed Block	S7033210	2	S7033210	2	S7063210	2	
8	Charging valve cover	S7033211	1	S7033211	1	S7063211	1	
9	Oil tube cover	S7033212	1	S7033212	1	S7063212	1	
10	Cover bolt	H41108020	8	H41108020	8	H41108020	8	
11	Connecting Bolt	H41120065	8	H41120065	8	H41120070	8	
12	Connecting nut	H48120110	16	H48120110	16	H48120110	16	
13	Cross shock block	B2061101	1	B2061101	1	B2061102	1	
14	Damping plate	B2067101	1	B2067102	1	B2067103	1	

## Case Parts accessories list

## BOX TYPE(NS68,NS75,NS100)

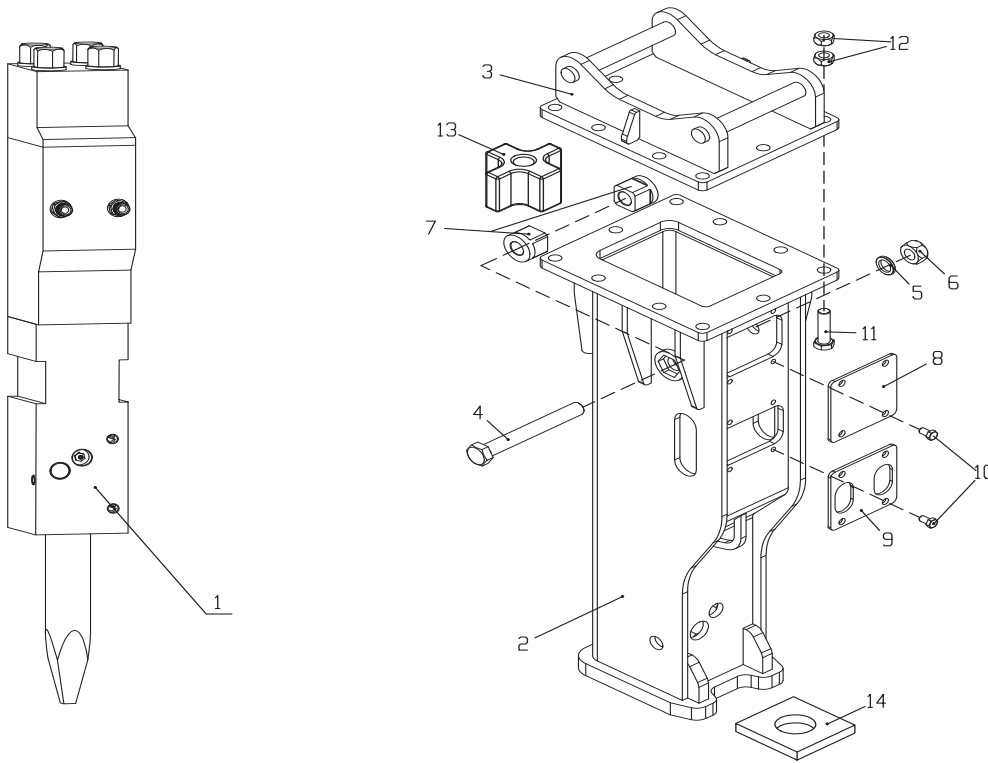

NO	PARTS NAME	NS68		NS75		NS100		REMARKS
		P/N	Qty	P/N	Qty	P/N	Qty	
	Frame Ass'y	S7073200	/	S7083200	/	S7113200	/	
1	Body Ass'y	S1071000	1	S1081000	1	S1111000	1	
2	Frame	S7073201	1	S7083201	1	S7113201	1	
3	Connecting Head	S7073202	1	S7083202	1	S7113202	1	
4	Flush Bolt	H41127220	1	H41130230	1	H41136315	1	
5	Washer	H49027300	1	H49030300	1	H49036300	1	
6	Side Bolt	H48127110	1	H48130110	1	H48136110	1	
7	Fixed Block	S7073210	2	S7083210	2	S7113210	2	
8	Charging valve cover	S7073211	1	S7083211	1	S7113211	1	
9	Oil tube cover	S7073212	1	S7083212	1	S7113212	1	
10	Cover bolt	H41112020	8	H41110020	8	H41112020	8	
11	Connecting Bolt	H41120075	10	H41120075	18	H41124095	14	
12	Connecting nut	H48120110	20	H48120110	36	H48124110	28	
13	Cross shock block	B2061103	1	B2061103	1	B2061105	1	
14	Damping plate	B2067104	1	B2067105	1	B2067206	1	

Case Parts accessories list

BOX TYPE(NS140A,NS155)

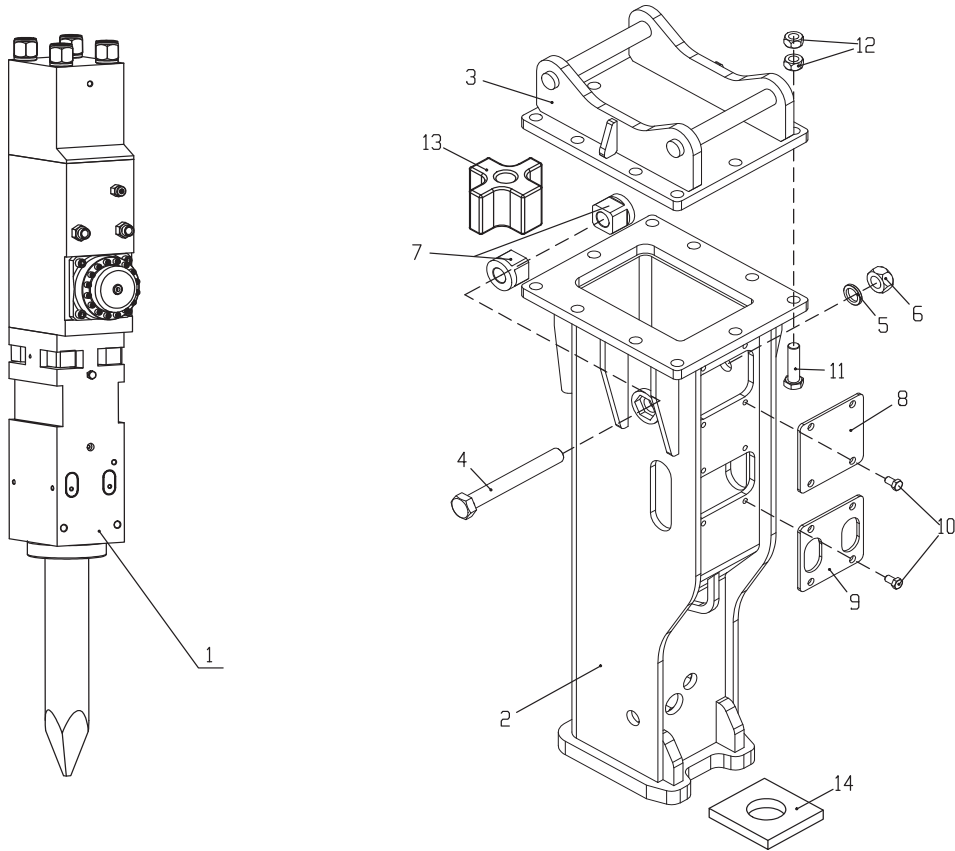

NO	PARTS NAME	NS140A		NS155		REMARKS
		P/N	Qty	P/N	Qty	
	Frame Ass'y	S7143200	/	S7223200	/	
1	Body Ass'y	S1151000	1	S1221000	1	
2	Frame	S7153201	1	S7223201	1	
3	Connecting Head	S7153202	1	S7223202	1	
4	Flush Bolt	H41148380	1	H41148415	1	
5	Washer	H49048300	1	H49048300	1	
6	Side Bolt	H48148110	1	H48148110	1	
7	Fixed Block	S7153210	2	S7223210	2	
8	Charging valve cover	S7153211	1	S7223211	1	
9	Oil tube cover	S7153212	1	S7223212	1	
10	Cover bolt	H41112020	10	H41112020	10	
11	Connecting Bolt	H41130115	16	H41130125	12	
12	Connecting nut	H48130110	32	H48130110	24	
13	Cross shock block	B2061108	1	B2061109	1	
14	Damping plate	B2067107	1	B2067208	1	

## TOOL AND TOOL BOX

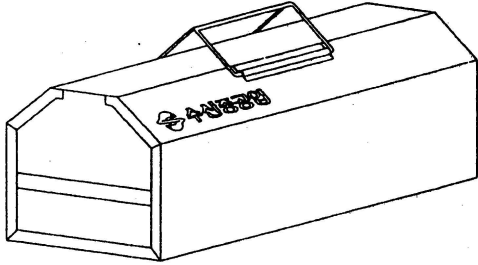

TOOL BOX

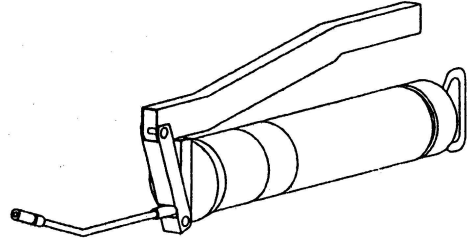

GREASE GUN

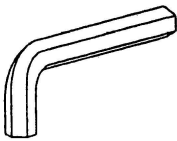

L-WRENCH

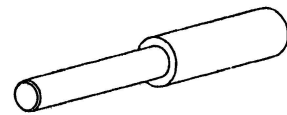

PIN BAR

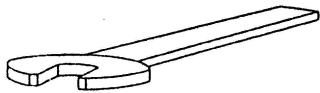

SINGLE SPANNER

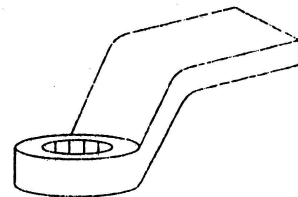

SINGLE RING SPANNER

## TOOL SET

TOOL	Q'ty	NS40	NS45	NS53	NS68	NS75	NS85	NS100	NS120	NS135A	NS140A	NS155	NS165	NS175	NS185	NS190	NS195
TOOL SET	1	B3032000	B3042000	B3062000	B3072000	B3082000	B3092000	B3112000	B3702000	B3132000	B3152000	B3222000	B3232000	B3252000	B3582000	B3592000	B3602000
TOOL BOX	1	B3001000 B3002000 B3003000															
NITROGEN GAS CYLINDER	1	B4001000							B4002000								
AIR CHARGING SYSTEM	1	B4000100															
GREASE NIPPLE SLEEVE	1	H3005114															
GREASE GUN	1								B3009100								
PIN OUTLET	1	B7008009			B7008015												
PIN CARRIER	1														B7008017		
INFORMATION PACK	1	M2001000							M2002000		M2001000				M2002000		
INSTRUCTION	1	M2001010							M2002010		M2001010				M2002010		
CERTIFICATION	1	M2031000	M2041000	M2061000	M2071000	M2081000	M2091000	M2111000	M2501000	M2701000	M2151000	M2221000	M2231000	M2251000	M2581000	M2591000	M2601000
MANUAL	1	M2001020							M2002020		M2001020				M2002020		
PARKING LIST	1	M2031010	M2041010	M2061010	M2071010	M2081010	M2091010	M2111010	M2501010	M2701010	M2151010	M2221010	M2231010	M2251010	M2581010	M2591010	M2601010
MONKEY SPANNER	1	H3006210															
SINGLE RING SPANNER	1	30mm H3003030	34mm H3003034	36mm H3003036	41mm H3003041	46mm H3003046		55mm H3003055		75mm H3003075		85mm H3003085				95mm H3003095	
SINGLE RING SPANNER	1	24mm H3003024	27mm H3003027	30mm H3003030			50mm H3003050		65mm H3003065							90mm H3003090	
SINGLE RING SPANNER	1		30mm H3003030														
OPEN SPANNER	1			27mm H3002027				32mm H3002032	34mm H3002034		30mm H3002030	50mm H3002050					
OPEN SPANNER	1										41mm H3002041						
OPEN SPANNER	1															55mm H3002055	
HEX SOCKET	1								17mm H3001017		10mm H3001010				12mm H3001012		
HEX SOCKET	1								19mm H3001019		14mm H3001014			17mm H3001017			
HEX SOCKET	1								10mm H3001010		19mm H3001019						
HEX SOCKET	1								12mm H3001012			5mm H3001005					
HEX SOCKET	1								14mm H3001014						22mm H3001022	24mm H3001024	
HEX SOCKET	1								5mm H3001005								22mm H3001022
HEX SOCKET	1																10mm H3001010

**Back Head Gas Charging Kit(Optional)**

NO	PARTS NO	Q' ty	PARTS NAME
	C61 204	1set	N2 GAS CHARGING SET
1	2900003	1	N2 GASCYLINDER
2	2651001	1	SYNFLEX HOSE
3	C91 142	1	B-3WAY VALVE ASSEMBLY
4	C91 122	1	BOMBE ADAPTER
5	C91 121	1	BOMBE ADAPTER NUT
6	F01 137	1	LONG ADAPTER:USE FOR BOX & SILENCE TYPE

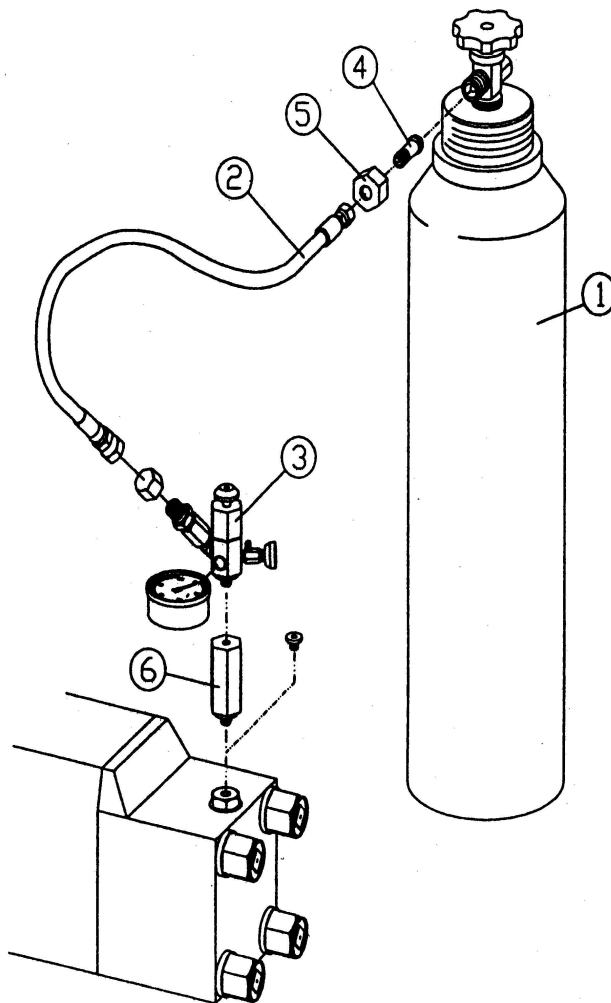

### Accumulator Charging Tool Set

NO	PARTS NO	Q'ty	PARTS NAME
	C61205	1set	ACCUMULATOR GAS CHARGING SET
1	C61204	1set	N2 GAS CHARGING SET
2	2850010	1	O-RING
3	U81414	1	O-RING-HEX BUSHING
4	2850014	1	O-RING

